



Read the manual and check the parts for completeness before assembly!

Images are illustrative and may differ from reality, the construction principle is the same.

USER MANUAL OF THE SAUNA

1. It is recommended to install the sauna above ground level to prevent the legs of the sauna from coming into direct contact with the ground. Install a water-resistant material, such as bitumen strips, between the legs of the sauna and the base.
2. Make sure that the surface on which you install the sauna is leveled and stable both before and after installing the sauna. Otherwise, the doors of the sauna may not open and close properly.
3. If the top part of the chimney has not been installed upon delivery of the sauna, it should be placed into the chimney pipe from the roof of the sauna.
4. During the first heating of the sauna, it must be constantly supervised and the doors should be kept open, as the stove emits a specific smell when first heated. Read more from the user manual of the sauna stove.
5. The maximum permitted temperature of the steam room is +90 °C. If heated to a higher temperature, the sauna may be overheated.
6. After each use of the sauna, it is recommended to keep the stove warm, the doors open, and the footrests up for a while to allow the sauna to dry from the inside. If necessary, the water on the floor should be directed to the drain with a floor scraper to avoid damage caused by excess humidity.
7. **When the weather is humid and if the wood has expanded, the metal hoops around the sauna should be loosened to avoid breaking the clamps and jamming the doors.** The hoops can be adjusted from the nut of clamp M12 located on the side of the sauna. To alleviate excess tension on the clamp and the hoop itself, loosen nut M12 (wrench no. 19) until the hoop can be shifted left and right. Then, righten the nut until the hoop is under slight pressure and pressed fully against the wood so that it cannot be pulled away from the walls of the sauna. **When the weather is less humid and the wood has dried, the metal hoops around the sauna should be tightened from nut M12.** Tighten the nut so the hoop is under slight pressure. The hoop must be pressed fully against the wood so that it cannot be pulled away from the walls of the sauna. **LEIL SAUNAS is not liable for damage caused to the sauna due to a broken hoop clamp.**
8. If the door is shifted out of place when the hoops are tightened, lift the exterior door off the hinges and regulate the hinges. If this is not a sufficient solution, remove the trims of the door and unscrew the screws of the doorframe beneath them. This will relieve the pressure on the door. If necessary, the opening of the door may be made wider, after which the screws should be re-tightened and the trims and door reinstalled.
9. The interior door should be regulated from the stopper and, if necessary, the hinges. If this is not a sufficient solution, remove the trims of the door and unscrew the screws of the doorframe beneath them. This will relieve the pressure on the door.
10. Locking the sauna door from the inside is prohibited.
11. In order to avoid damage caused by the weight of snow, any snow should be removed from the roof of the sauna. Keep in mind that the roof covering should not be damaged during snow removal.
12. If your sauna has lighting, install a 3G 2,5 mm² outdoor power cable and connect it in junction box provided with the sauna (L1 – brown , N – blue , GR – green-yellow). The power cable of the sauna must be connected to a residual-current circuit breaker! Consult an electrician if necessary.

Maintenance of the sauna

1. **The interior surfaces of the sauna, the window frames of the steam and washing room, and the frames of interior doors must be treated with a special substance before initial use to protect them from humidity and dirt and extend the useful life of the sauna.** Later, this should be done once or twice a year. TEKNOS Satu Saunasuoja or Tikkurila Supi Saunasuoja may be used for this.
2. **Before initial use of the sauna, the benches and footrests must be treated with a protective oil to extend their useful life.** Later, this should be done once or twice a year. TEKNOS Satu Laudesuoja or Tikkurila Supi Laudesuoja or something similar high-temperature resistant interior wood varnish may be used for this.
3. **The exterior surfaces of the sauna are given the first protective coating during production (DIY saunas are not treated). The second coating should be applied approximately two months after purchasing the sauna to extend its useful life and maintain its appearance.** Remmers Aidol HK-Lasur or something similar weather-resistant exterior wood varnish may be used for this.
4. **LEIL SAUNAS is not liable for damage caused to the sauna due to insufficient maintenance or no maintenance at all.**

WARRANTY

- The products have a 24-month warranty covering material and production defects, taking effect from the delivery of the sauna to the client.
- The warranty is valid if the user has reviewed the user manuals and abides by them.
- Please note! The warranty period differs for products on trailers and products intended for commercial use.
- The warranty does not cover defects characteristic of wood, such as discoloration, changes, issues, or cracks caused by alternating or excess humidity, etc.
- The warranty does not cover cracking of the bitumen sealant between the roof covering and the end arches due to drying of the wooden material. If the sealant cracks, the old sealant must be replaced with a new one (ROOF REPAIR SEALANT SOUDAL ROOF REPAIR 310 or similar).
- The warranty does not cover normal wear and tear of the product caused by its use and damage caused by incorrect installation or use is not compensated.
- The warranty does not cover damage caused by thunder or other weather phenomena.
- The warranty does not cover damage caused by incorrect installation by the client.
- The warranty expires when attempts are made to independently change or fix the product or if it is not used for its intended purpose.
- The warranty is void if the product is stored in an incorrect position or in the wrong conditions.
- The warranty is valid if the buyer informs the seller of the defect within a reasonable time (7 days).

CONTENTS

- Exterior construction (Drawing):	BLACK Cube Classic (L-benches) views BLACK Cube Classic (L-benches) options
- Bench assembly (Drawing):	BLACK Cube Classic (L-benches) sectional views from inside
- Exterior construction (Detail list):	Detail list 1 Detail list 2 Detail list 3 (Optional) Detail list 4
- Bench assembly:	Detail list 5 Detail list 6 (Optional) Detail list 7 Detail list 8
- Tools and materials:	
- Exterior construction:	Floor construction and preparation 1.1 - 1.6 Preparation of the walls 2.1 - 2.4 Construction of walls 3.1 - 3.7 Roof preparation and construction 4.1 - 4.7 Installation of doors and vent covers 5.1 - 5.5
- Bench assembly:	benches, grates, etc. 6.1 - 6.9 Installation of the heater wall mounting module(s)..... 7.1 - 7.3 Installation of the bench skirt (left side bench)..... 8.1

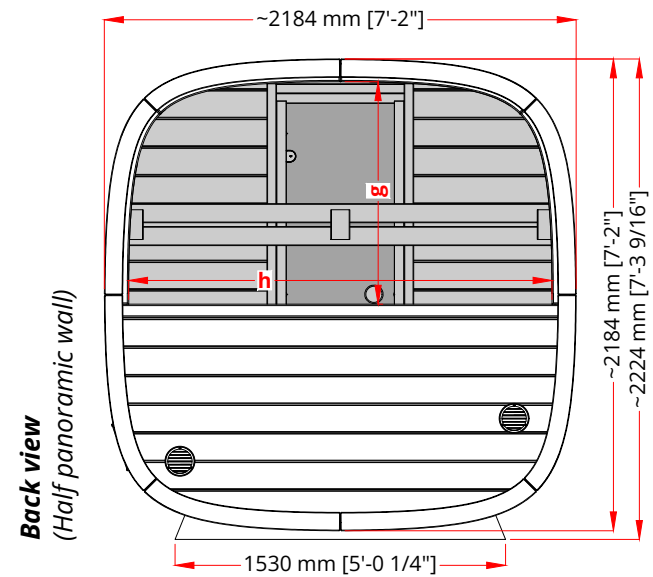
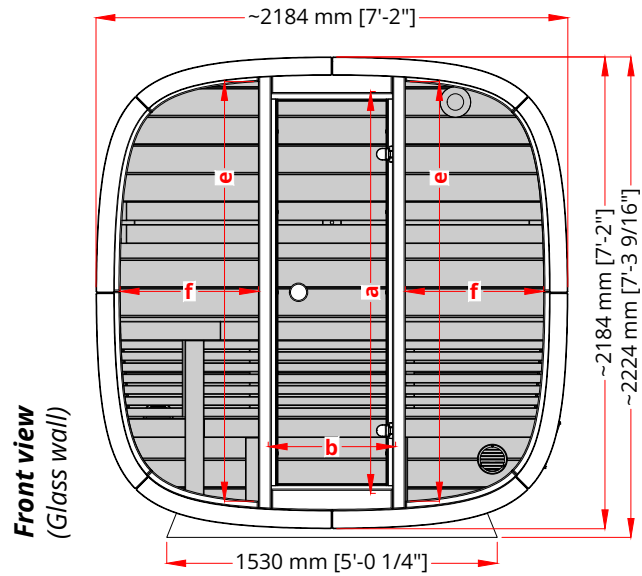

BLACK Cube Classic		
a	1860 mm	~ 6'-1 1/4"
b	590 mm	~ 1'-11 1/4"
c	1200 mm	~ 3'-11 1/4"
d	350 mm	~ 1'-1 3/4"
e	~1942 mm	~ 6'-4 1/2"
f	~640 mm	~ 2'-1 3/16"
g	~1030 mm	~ 3'-4 9/16"
h	~1960 mm	~ 6'-5 1/8"

BLACK Cube Classic (L-benches)

Exterior construction (Drawing)

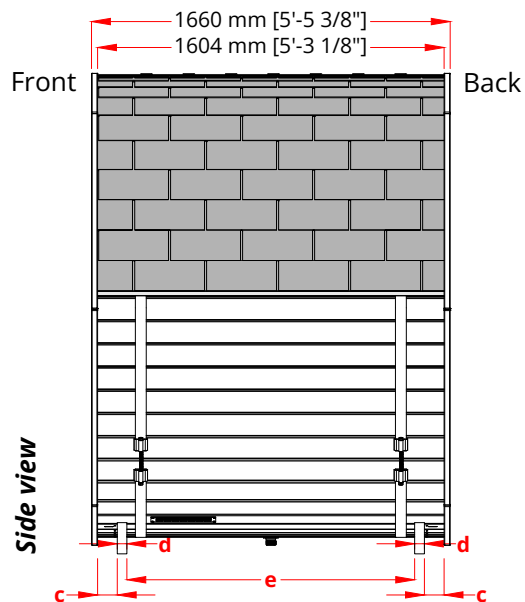
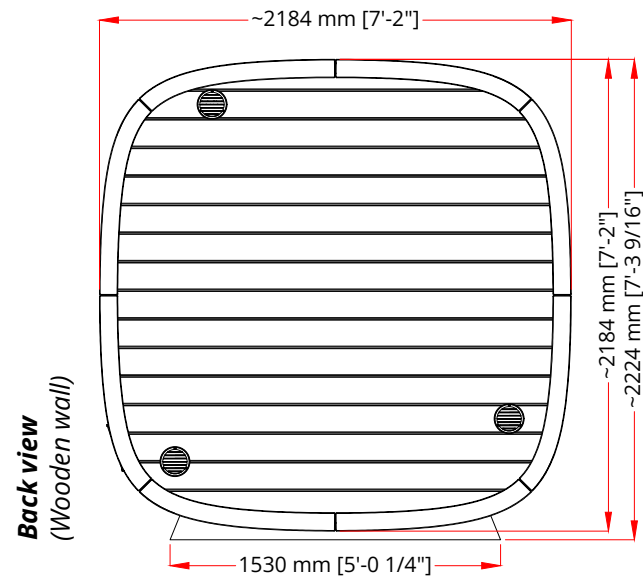
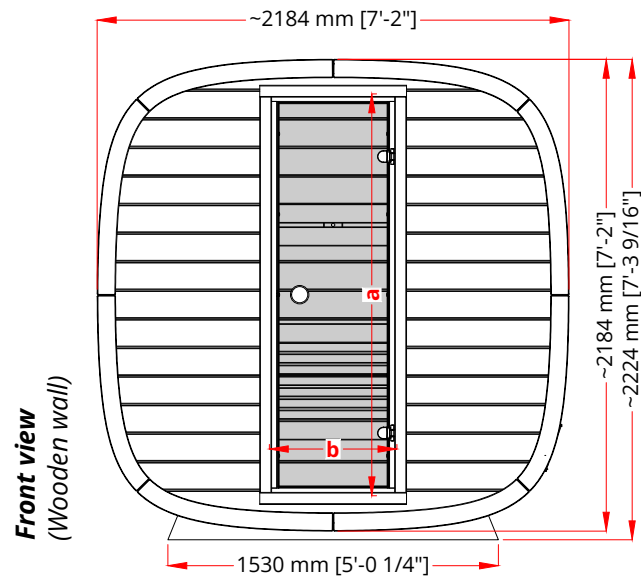

BLACK Cube Classic		
a	1860 mm	~ 6'-1 1/4"
b	590 mm	~ 1'-11 1/4"
c	91 mm	~ 0'-3 9/16"
d	45 mm	~ 0'-1 3/4"
e	~1332 mm	~ 4'-4 7/16"

BLACK Cube Classic
(L-benches)
views

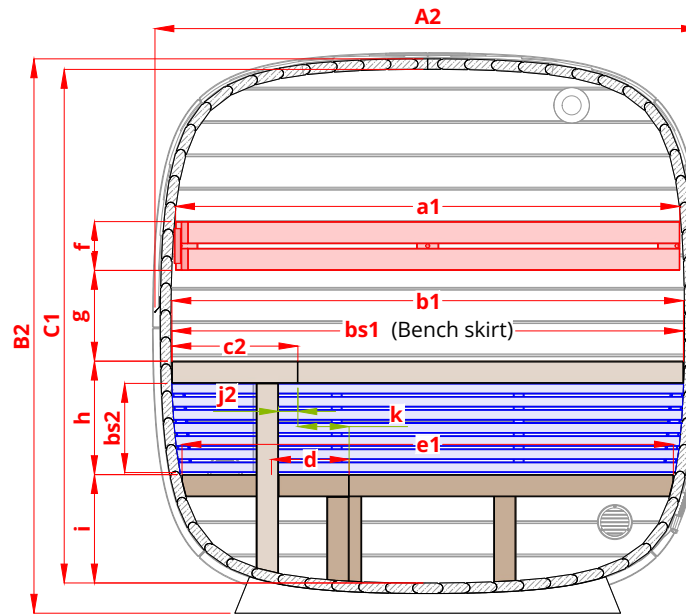
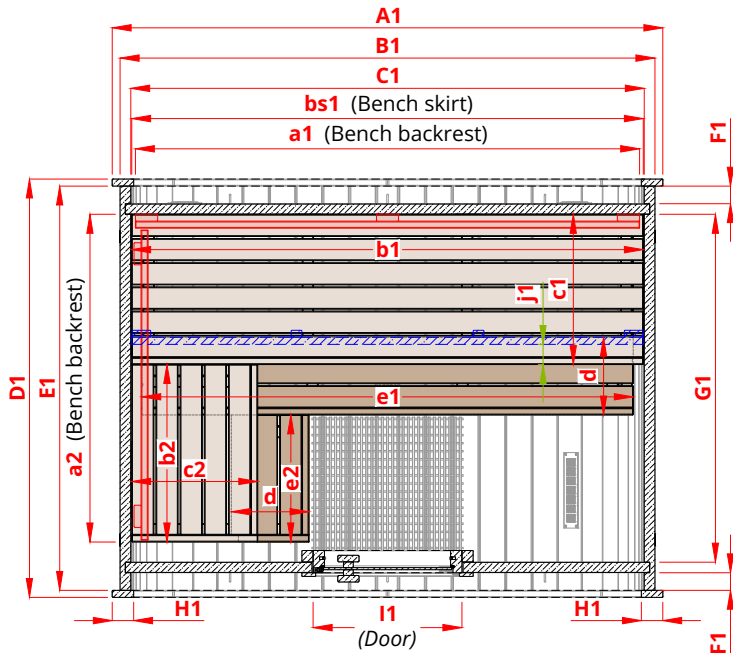

Dimensions and lengths		
A1	~ 2184 mm	~7'-2"
B1	~ 2122 mm	~6'-11 1/2"
C1	~ 2038 mm	~6'-8 1/4"
D1	1660 mm	~5'-5 3/8"
E1	1604 mm	~5'-3 1/8"
F1	70 mm	~0'-2 3/4"
G1	1380 mm	~4'-6 5/16"
H1	85 mm	~0'-3 3/8"
I1	590 mm	~1'-11 1/4"
A2	~ 2165 mm	~7'-1 1/4"
B2	~ 2200 mm	~7'-2 5/8"

Dimensions and lengths		
a1	2000 mm	~6'-6 3/4"
a2	1300 mm	~4'-3 3/16"
b1	2030 mm	~6'-7 15/16"
b2	704 mm	~2'-3 11/16"
bs1	2030 mm	~6'-7 15/16"
bs2	354 mm	~1'-1 15/16"
c1	~ 596 mm	~1'-11 7/16"
c2	~ 500 mm	~1'-7 11/16"
d	~ 308 mm	~1'-0 1/8"
e1	1950 mm	~6'-4 3/4"
e2	504 mm	~1'-7 13/16"
f	194 mm	~0'-7 5/8"
g	360 mm	~1'-2 3/16"
h	450 mm	~1'-5 11/16"
i	430 mm	~1'-4 15/16"
j1	~ 80 mm	~0'-3 1/8"
j2	~ 77 mm	~0'-3 1/16"
k	~ 203 mm	~0'-8"

BLACK Cube Classic
(L-benches)

Sectional views from inside

Detail profiles

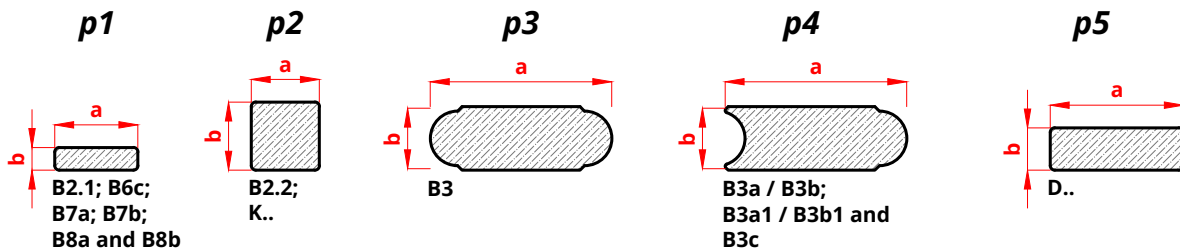

	a	b	a	b
p1	~55 mm	~15 mm	~ 0'-2 3/16"	~ 0'-0 9/16"
p2	~45 mm	~45 mm	~ 0'-1 3/4"	~ 0'-1 3/4"
p3	~120 mm	~40 mm	~ 0'-4 3/4"	~ 0'-1 9/16"
p4	~120 mm	~40 mm	~ 0'-4 3/4"	~ 0'-1 9/16"
p5	~88 mm	~28 mm	~ 0'-3 7/16"	~ 0'-1 1/8"

Dimensions and lengths		
B2.2 - Length	~2080 mm	~ 6'-9 7/8"
A1 - Length	~560 mm	~ 1'-10 1/16"

* Door molding **B7a** will be removed during construction.

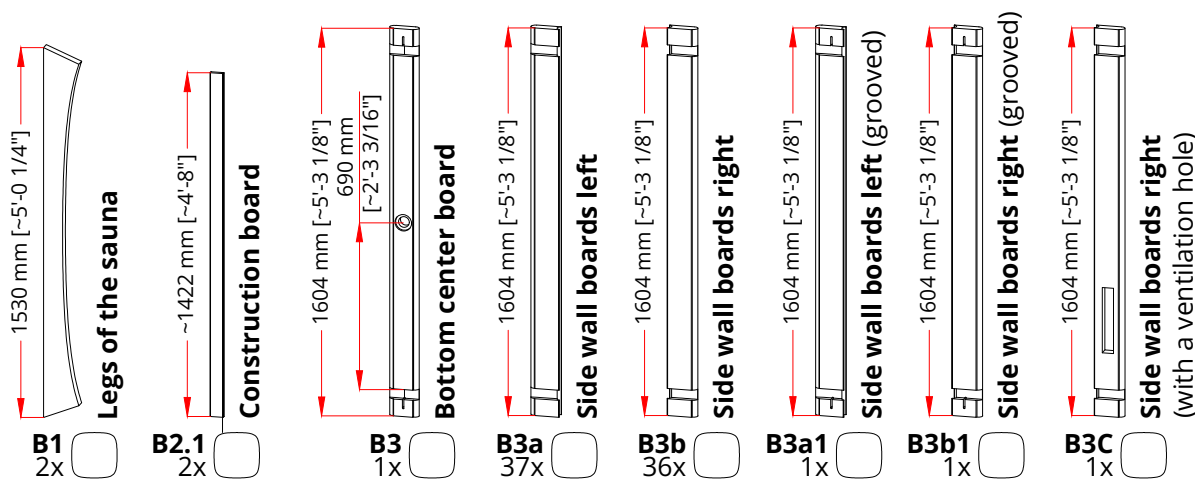
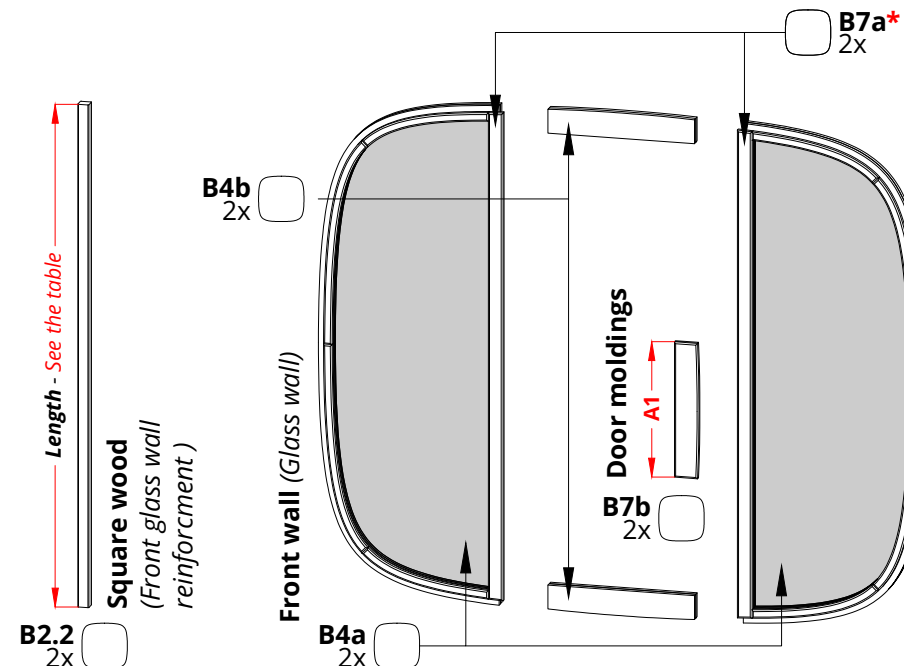

B3a and B3b look the same.
For construction, divide into equal quantities

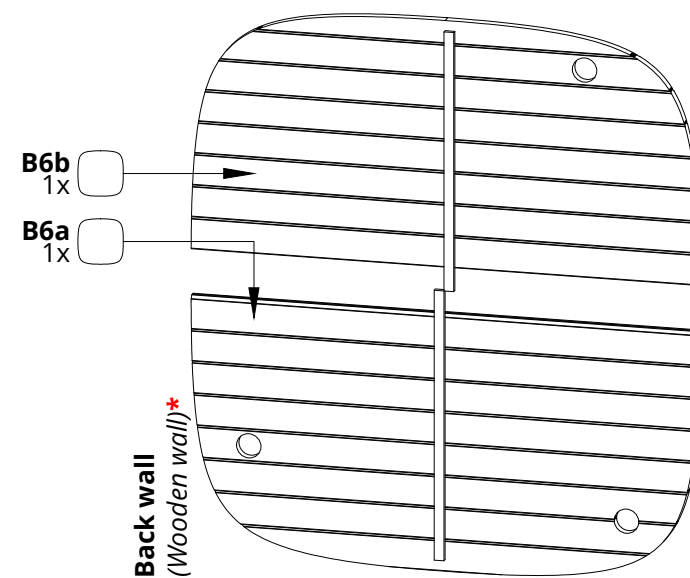

Detail list 1

Exterior construction

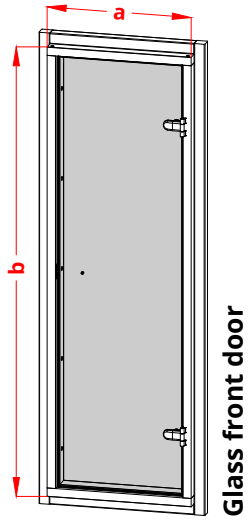

Glass front door

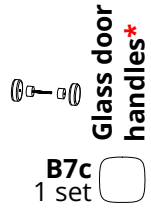

B7c
1 set

Glass door handles*

B7
1x

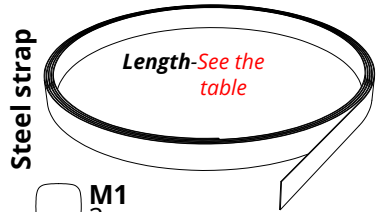

Steel strap

M1
2x

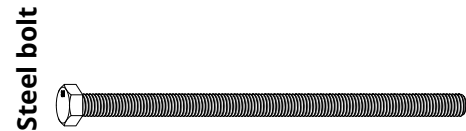

Steel bolt

M2
2x



Steel washer

M3
4x



Steel hex nut

M4
2x

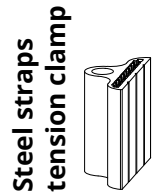

Steel straps tension clamp

M5
4x



Rubber seal

R1
2x

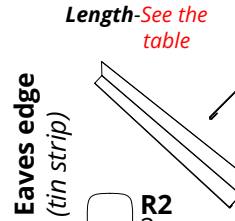

Eaves edge (tin strip)

R2
2x

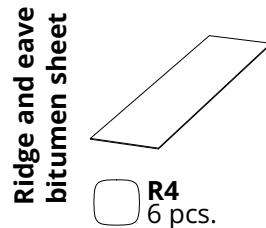

Ridge and eave bitumen sheet

R4
6 pcs.

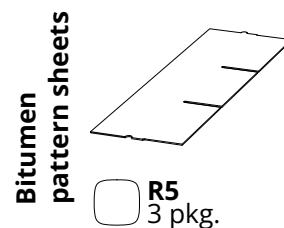

Bitumen pattern sheets

R5
3 pkg.

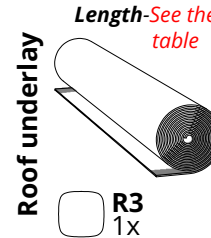

Roof underlay

R3
1x

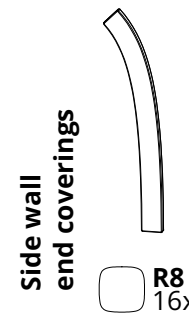

Side wall end coverings

R8
16x



Piece of drain pipe

V1
1x

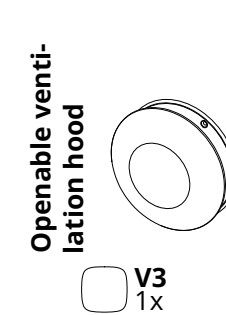

Openable ventilation hood

V3
1x

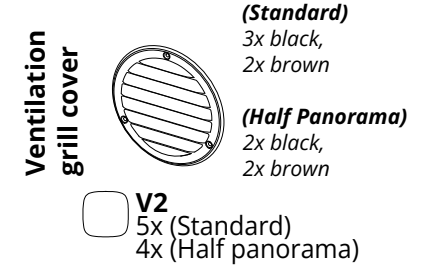

Ventilation grill cover

V2
5x (Standard)
4x (Half panorama)

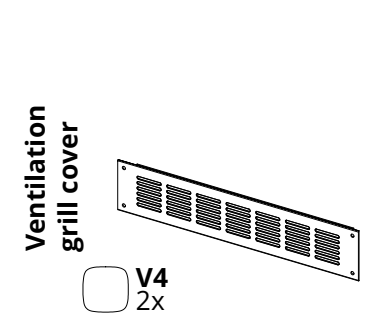

Ventilation grill cover

V4
2x

Dimensions and lengths					
a	590 mm	~ 1'-11 1/4"	M1 - Length	~7.9 m	~ 25'-11"
b	1860 mm	~ 6'-1 1/4"	R1 - Length	~1.6 m	~ 5'-3"
			R2 - Length	~1.6 m	~ 5'-3"
			R3 - Length	~1.7 m	~ 5'-6 15/16"

Wood protection and sealing materials

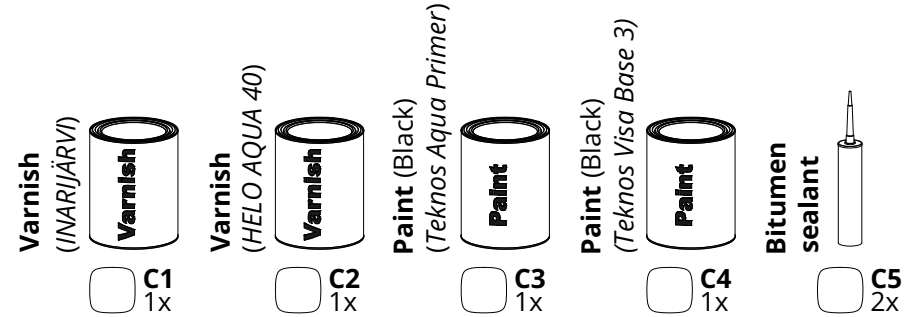

Varnish (INAR/JÄRVI)
C1
1x

Varnish (HELO AQUA 40)
C2
1x

Paint (Black) (Teknos Aqua Primer)
C3
1x

Paint (Black) (Teknos Visa Base 3)
C4
1x

Bitumen sealant
C5
2x

Detail list 2

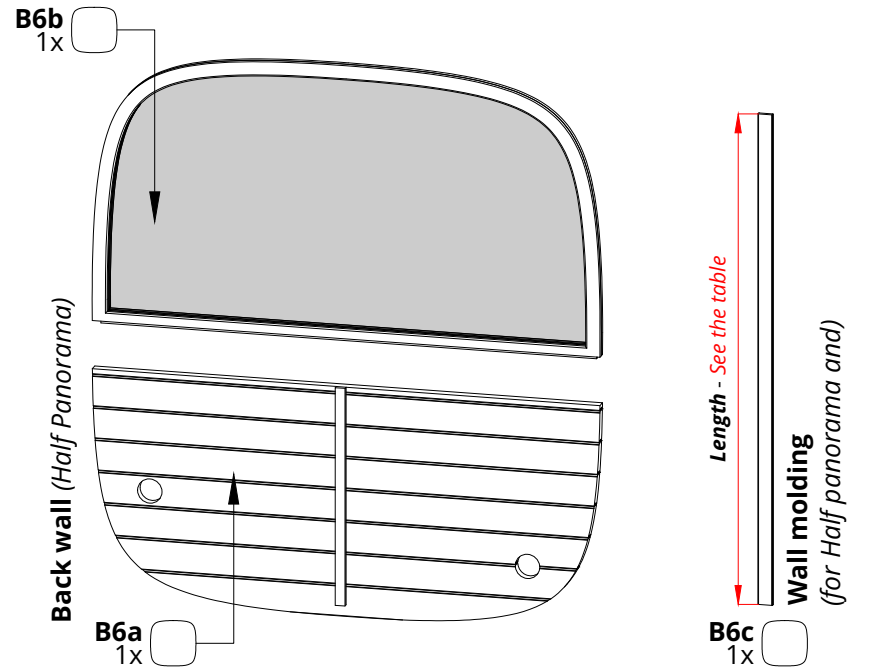
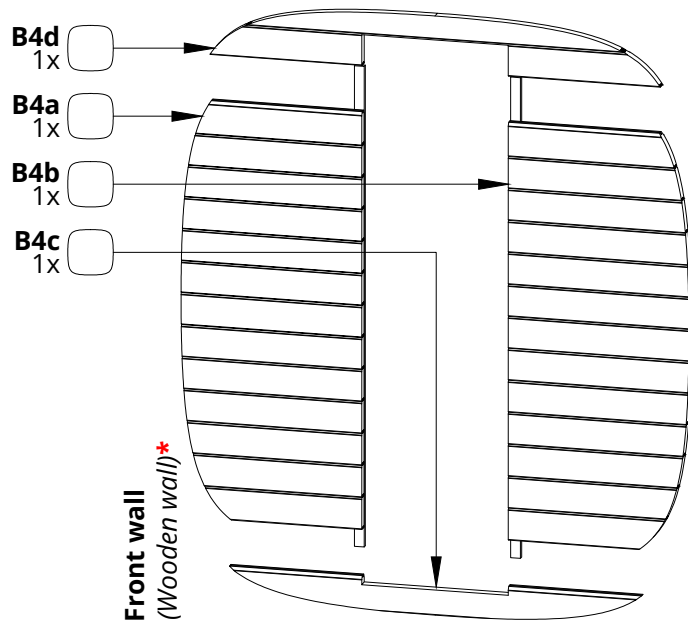







Dimensions and lengths		
B6c - Length	~2030 mm	~ 6'-7 15/16"

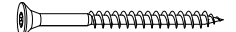
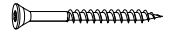
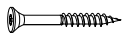

Detail list 3 (Optional)

Exterior construction

Fasteners for the main construction of the sauna:

Name in manual	Nails and screws / Screw size	Quantity	
S7	 4,5x80mm [~3/16x~3 1/8] for Spruce	50	<input type="checkbox"/>
	 4,2x75mm [~3/16x~2 15/16] for Thermo		
S6.1	 (Black coated) 4,5x70mm [~3/16x~2 3/4]	50	<input type="checkbox"/>
S5	 4,5x60mm [~3/16x~2 3/8] for Spruce	140	<input type="checkbox"/>
	 4,2x55mm [~3/16x~2 3/16] for Thermo		
S2	 3x40mm [~1/8x~1 9/16]	10	<input type="checkbox"/>
S1	 3x30mm [~3/16x~1 15/16]	40	<input type="checkbox"/>
R6	 Nail 2,5x20mm [~1/8x~13/16]	0.5kg	<input type="checkbox"/>



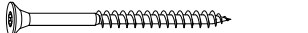
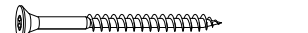

Fasteners for sauna door(s):

Name in manual	Nails and screws / Screw size	Quantity	
S6.2	 4,2x75mm [~3/16x~2 15/16]	20	<input type="checkbox"/>
S3.2	 (Nano black coating) 4,5x50mm [~3/16x~1 15/16]	20	<input type="checkbox"/>
P	 Hole plug	15	<input type="checkbox"/>

(OPTIONAL) Fasteners for Front glass wall:

Name in manual	Nails and screws / Screw size	Quantity	
S5	 4,5x60mm [~3/16x~2 3/8] for Spruce	15	<input type="checkbox"/>
	 4,2x55mm [~3/16x~2 3/16] for Thermo		

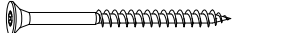
(OPTIONAL) Fasteners for Half Panoramic back wall:

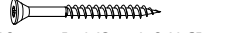
Name in manual	Nails and screws / Screw size	Quantity	
S7	 4,5x80mm [~3/16x~3 1/8] for Spruce	5	<input type="checkbox"/>
	 4,2x75mm [~3/16x~2 15/16] for Thermo		
S5	 4,5x60mm [~3/16x~2 3/8] for Spruce	5	<input type="checkbox"/>
	 4,2x55mm [~3/16x~2 3/16] for Thermo		
S2	 3x40mm [~1/8x~1 9/16]	5	<input type="checkbox"/>

Detail list 4

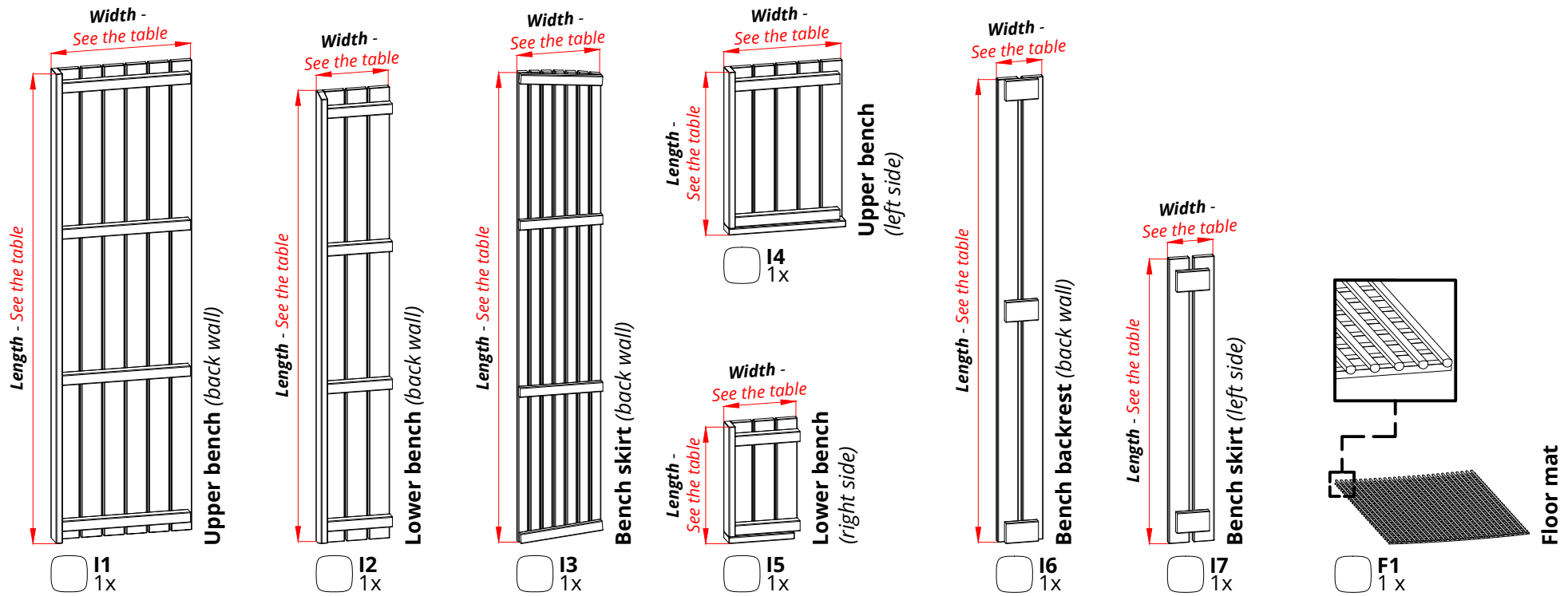

Heater attachment and installation (OPTIONAL)

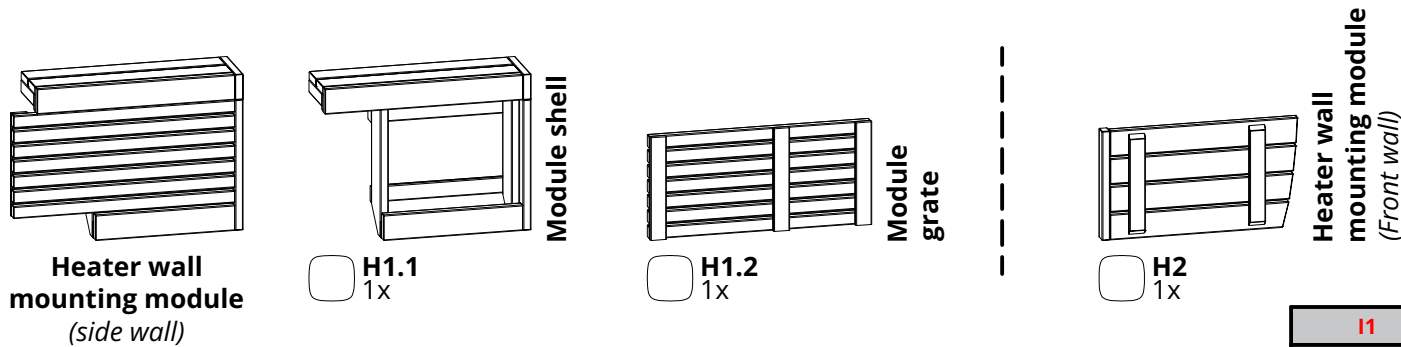

	Lengths	Width	Lengths	Width
I1	2030 mm	~ 596 mm	~ 6'-7 15/16"	~ 1'-11 7/16"
I2	1950 mm	~ 308 mm	~ 6'-4 3/4"	~ 1'-0 1/8"
I3	2030 mm	~ 354 mm	~ 6'-7 15/16"	~ 1'-1 15/16"
I4	704 mm	~ 500 mm	~ 2'-3 11/16"	~ 1'-7 11/16"
I5	504 mm	~ 308 mm	~ 1'-7 13/16"	~ 1'-0 1/8"
I6	2000 mm	~ 194 mm	~ 6'-6 3/4"	~ 0'-7 5/8"
I7	1230 mm	~ 194 mm	~ 4'-0 7/16"	~ 0'-7 5/8"

Detail list 5

Bench assembly

Square wood and Cover boards for the Bench assembly:

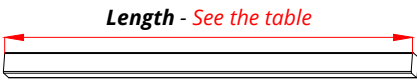
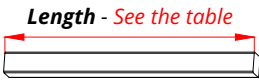
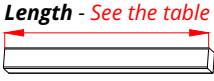
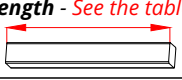
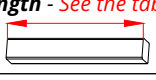
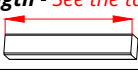
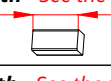
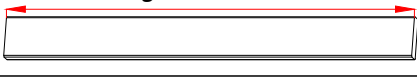
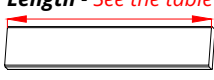
Name in manual	K... Square woods and D... Cover boards	Quantity
K90		1 <input type="checkbox"/>
K55		2 <input type="checkbox"/>
K45		4 <input type="checkbox"/>
K36		2 <input type="checkbox"/>
K30		1 <input type="checkbox"/>
K28		3 <input type="checkbox"/>
K10		2 <input type="checkbox"/>
D1		1 <input type="checkbox"/>
D2		6 <input type="checkbox"/>

(OPTIONAL) Square wood for Heater wall mounting module (side wall):

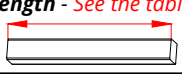



Name in manual	K... Square woods and D... Cover boards	Quantity
K36		1 <input type="checkbox"/>

Dimensions and lengths		
K90 - Length	900 mm	~ 2'-11 7/16"
K55 - Length	550 mm	~ 1'-9 5/8"
K45 - Length	450 mm	~ 1'-5 11/16"
K36 - Length	360 mm	~ 1'-2 3/16"
K30 - Length	300 mm	~ 0'-11 13/16"
K28 - Length	280 mm	~ 0'-11"
K10 - Length	100 mm	~ 0'-3 15/16"
D1 - Length	900 mm	~ 2'-11 7/16"
D2 - Length	450 mm	~ 1'-5 11/16"

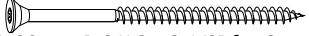

Detail list 6

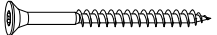
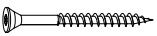
Bench assembly

Fasteners for the Bench assembly:

Name in manual	Nails and screws / Screw size	Quantity
S7	 4,5x80mm [$\sim 3/16 \times \sim 3 \ 1/8$] for Spruce	40 <input type="checkbox"/>
	 4,2x75mm [$\sim 3/16 \times \sim 2 \ 15/16$] for Thermo	
S5	 4,5x60mm [$\sim 3/16 \times \sim 2 \ 3/8$] for Spruce	50 <input type="checkbox"/>
	 4,2x55mm [$\sim 3/16 \times \sim 2 \ 3/16$] for Thermo	
S2	 3x40mm [$\sim 1/8 \times \sim 1 \ 9/16$]	5 <input type="checkbox"/>
P	 Hole plug	10 <input type="checkbox"/>

(OPTIONAL) Fasteners for Heater wall mount module (side wall):

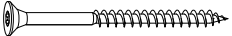
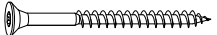
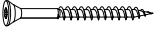
Name in manual	Nails and screws / Screw size	Quantity
S7	 4,5x80mm [$\sim 3/16 \times \sim 3 \ 1/8$] for Spruce	5 <input type="checkbox"/>
	 4,2x75mm [$\sim 3/16 \times \sim 2 \ 15/16$] for Thermo	
S5	 4,5x60mm [$\sim 3/16 \times \sim 2 \ 3/8$] for Spruce	15 <input type="checkbox"/>
	 4,2x55mm [$\sim 3/16 \times \sim 2 \ 3/16$] for Thermo	
S3.2	 4,5x50mm [$\sim 3/16 \times \sim 1 \ 15/16$]	5 <input type="checkbox"/>

(OPTIONAL) Fasteners for Heater wall mount module (front wall):

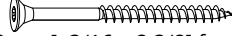
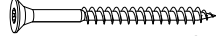
Name in manual	Nails and screws / Screw size	Quantity
S5	 4,5x60mm [$\sim 3/16 \times \sim 2 \ 3/8$] for Spruce	10 <input type="checkbox"/>
	 4,2x55mm [$\sim 3/16 \times \sim 2 \ 3/16$] for Thermo	

Tools needed for sauna construction:

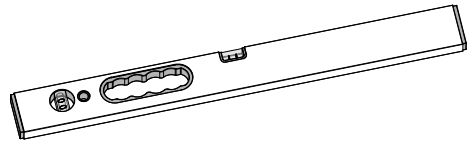

- Spirit level /
Laser level (best option)



- Tape measure /
folding rule



- Marking tool - pencil
(do not use a marker pen)

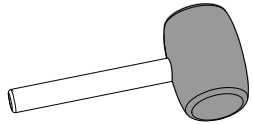

- Rubber hammer

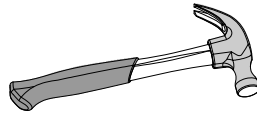

- Hammer

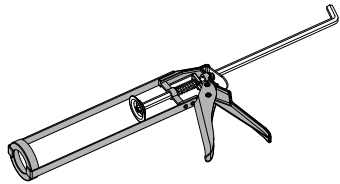

- Sealant gun

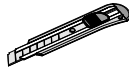

- Utility knife

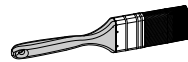

- Paintbrush

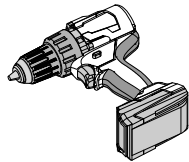

- Cordless drill(s)

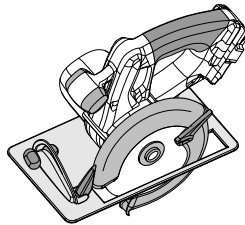

- Circular saw

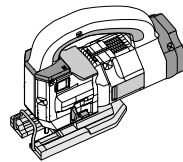

- Jigsaw / hand saw

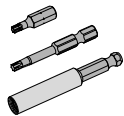

- Screwdriver bits

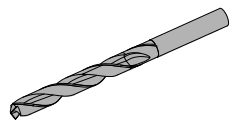

- drill bits (Ø3mm;
Ø4mm and Ø10-12mm)

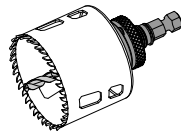

- hole saw (Ø68mm and Ø44mm)
for cutting a hole for the drain pipe (only necessary
if there is no hole in the s center board!)

Additional materials required, if not ordered or included:



- Wood glue /
assembly adhesive

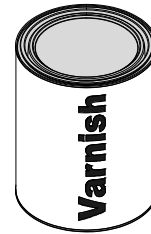

- Varnish
(to protect wood
from moisture
and mold)

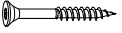

- Paint or wood oil
for wood protection
(external surfaces of sauna)

Screw(s)* 	Name:	Quantity:
	S7	4

*Screw dimensions - exterior construction detail list

NB! use a level

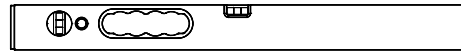

The base of the sauna must be level!

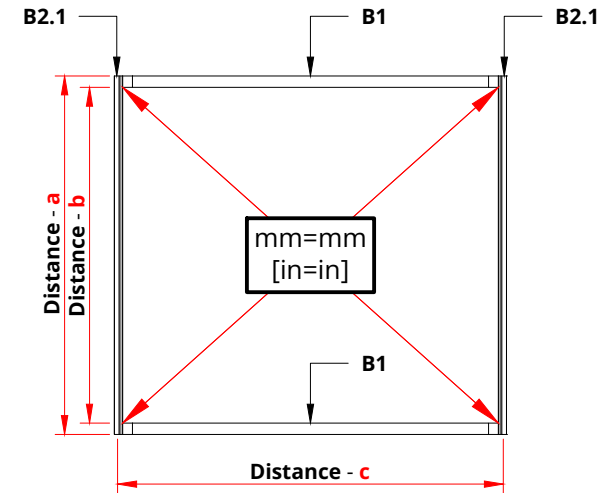
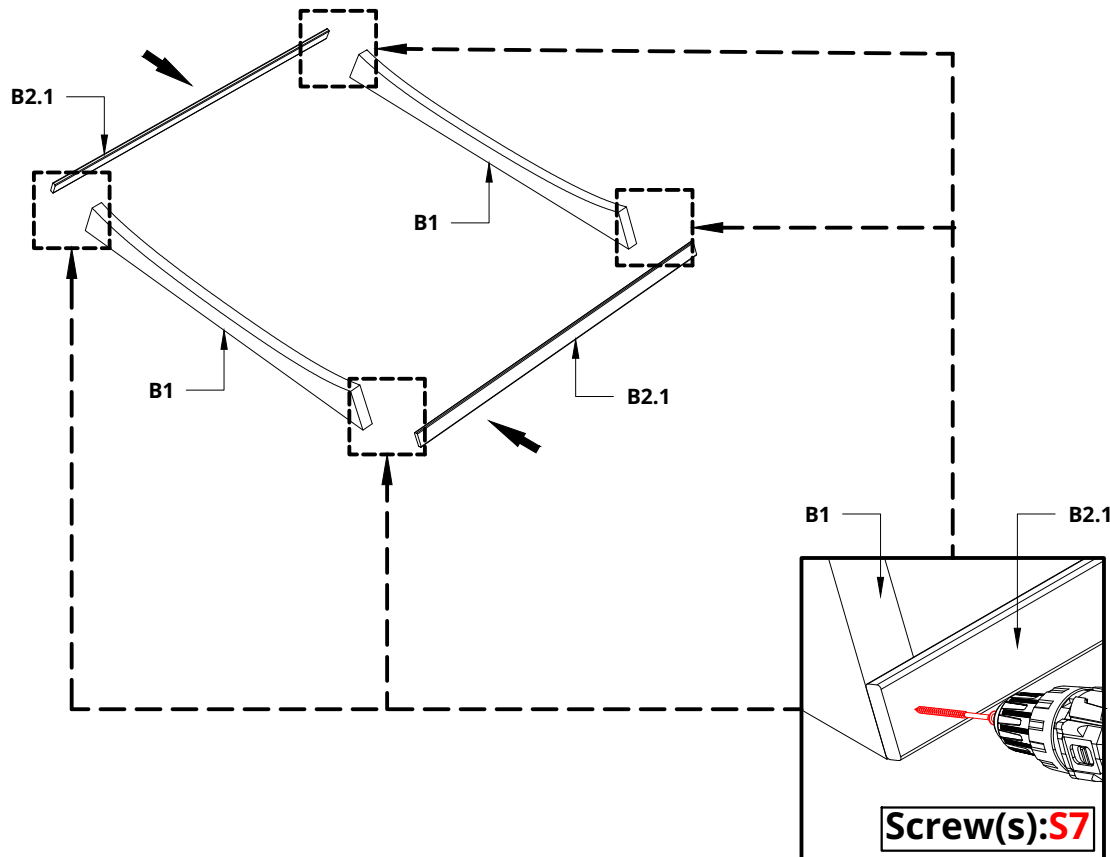

BLACK Cube Classic		
Distance - a	1422 mm	~ 4'-8"
Distance - b2	~1332 mm	~ 4'-4 7/16"
Distance - c	1530 mm	~ 5'-0 1/4"

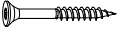
Screw(s)*	Name:	Quantity:
	S7	4

*Screw dimensions - exterior construction detail list

Please countersink the screw head(s)!

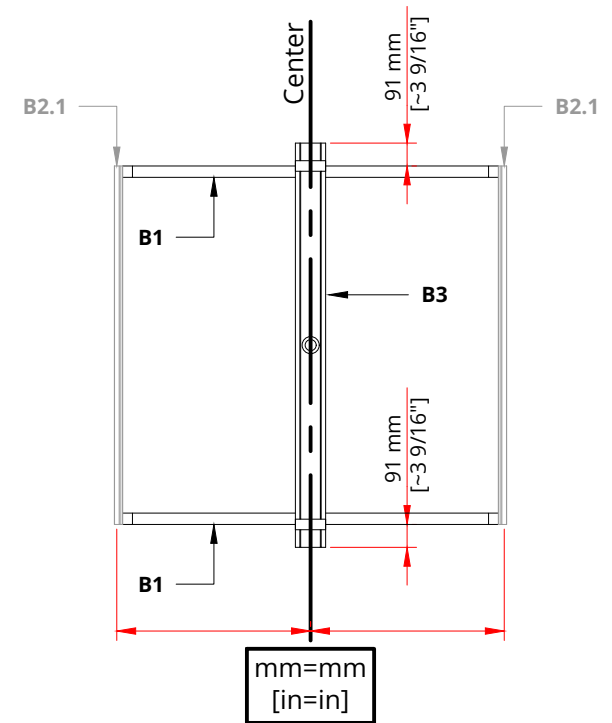
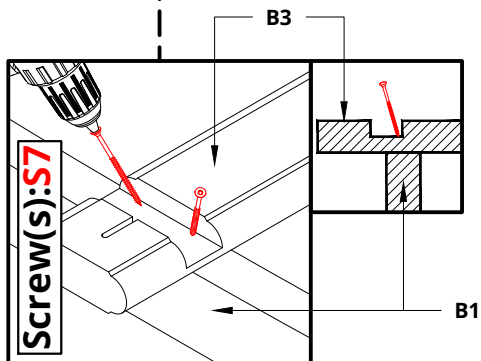
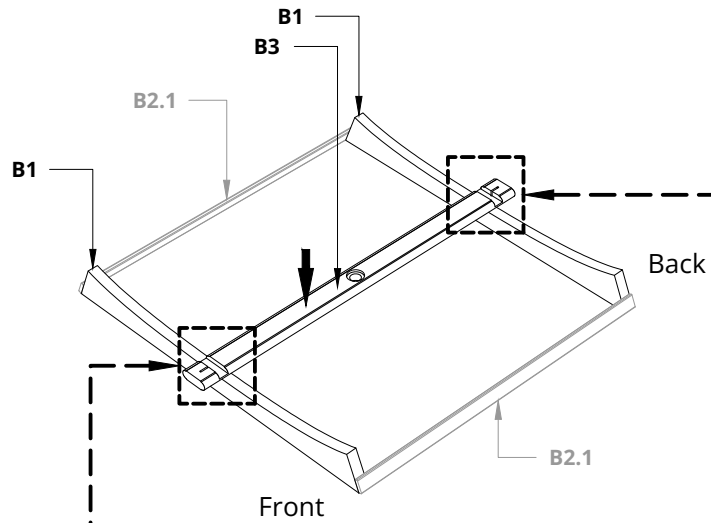
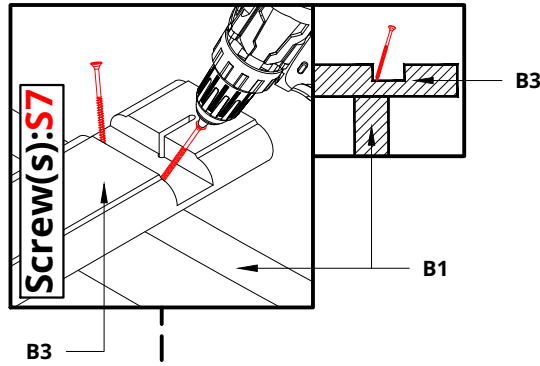

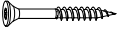
Screw(s)*	Name:	Quantity:
	S7	24

*Screw dimensions - exterior construction detail list

Please countersink the screw head(s)!

Use a rubber mallet to tap the board(s) together and fasten them with screws!

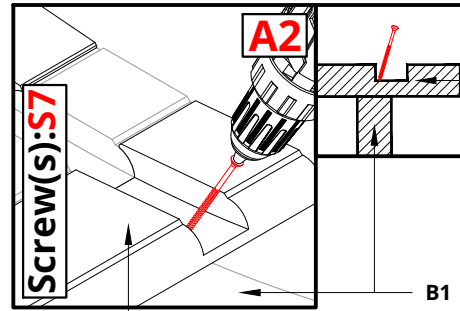

B3a Left and B3b Right

B3a Left and B3b Right

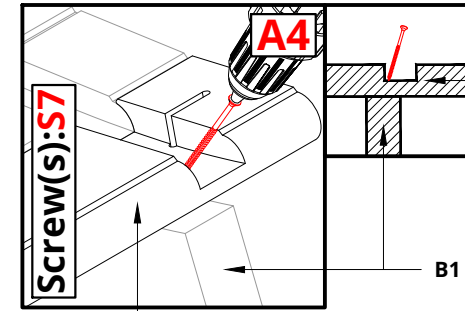

B3a1 Left and B3b1 Right

B3a1 Left and B3b1 Right

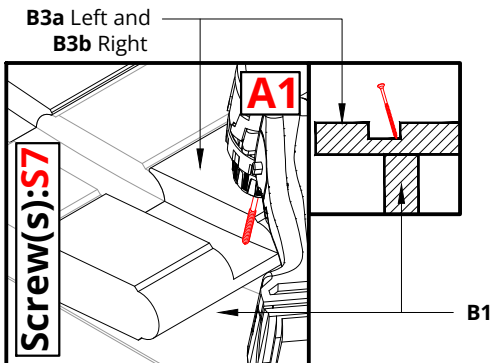
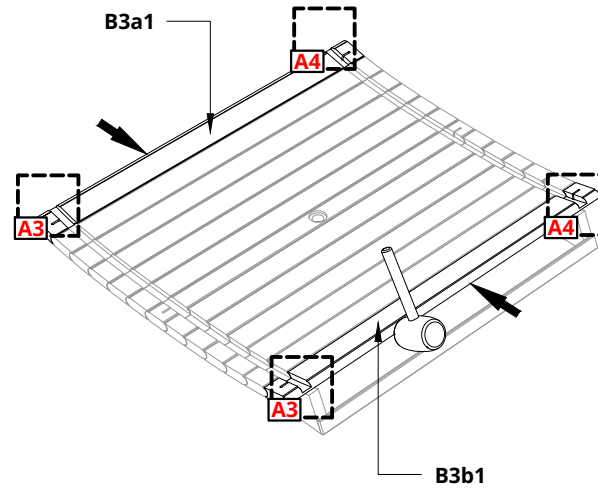
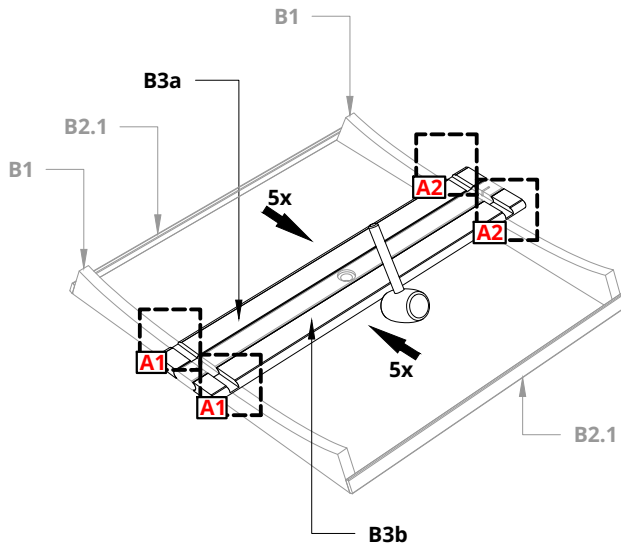

B3a Left and B3b Right

B1

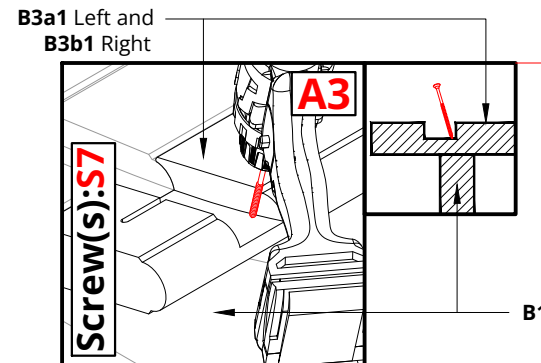

B3a1 Left and B3b1 Right

B1

Cut a hole for the drain pipe *(only necessary if there is no hole)*!

Drill 10 - 12 mm [0'-0 3/8" - 0'-0 1/2"] hole in each board groove!

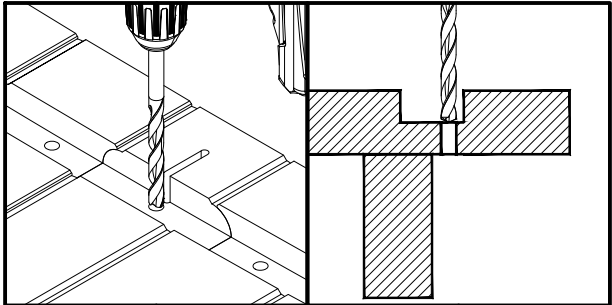

The measurement is from the inner edge of the groove.

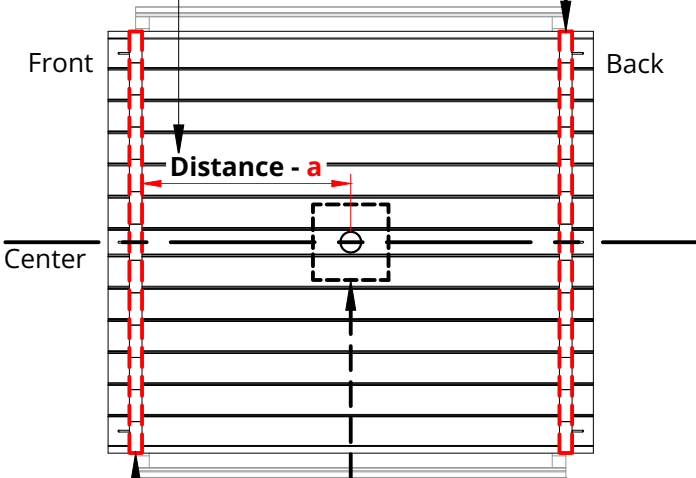

Only necessary if there is no drain pipe hole

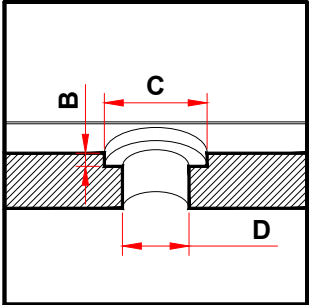
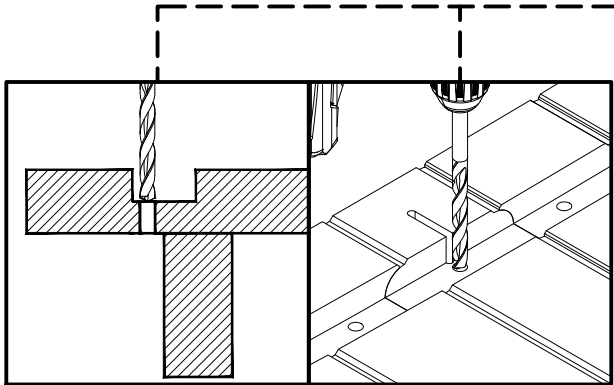

BLACK Cube Classic		
Distance - a	690 mm	~ 2'-3 3/16"
B	~10 mm	~ 0'-0 3/8"
C	68 mm	~ 0'-2 11/16"
D	44 mm	~ 0'-1 3/4"

Clean the groove and floor surfaces from wood waste and other dirt!
 Cover the grooves and the floor surfaces (middle) with varnish!*

Use paint or wood oil at the front end and back end of the board(s)!*

* Follow the manufacturer's instructions!

Add 2 coats of varnish*

C1:Varnish
(INARIJÄRV)

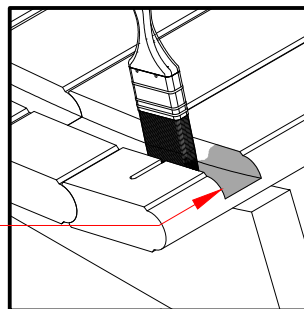

Add 2 coats of varnish*

C1:Varnish
(INARIJÄRV)

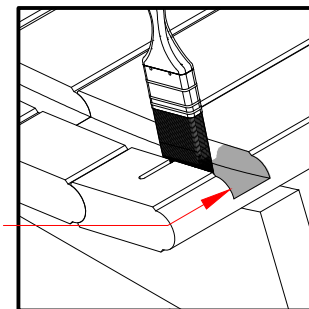

Front

Back

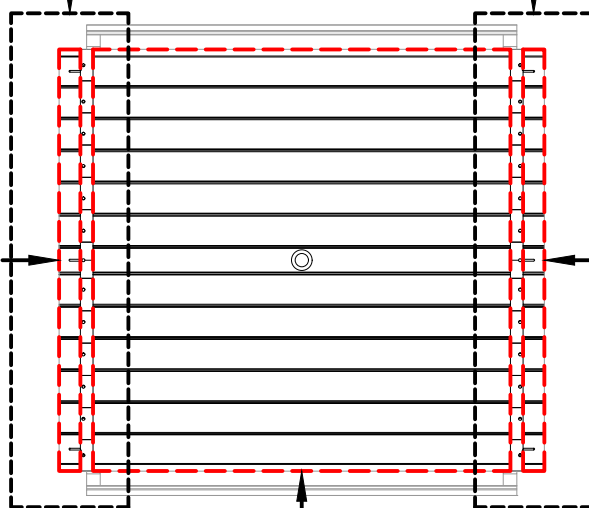

Add 1-2 coats of paint*

(First coats of paint **C3**,
Second coat of paint **C4**)

C3:Paint (Black)
(Teknos Aqua Primer)
C4:Paint (Black)
(Teknos Visa Base 3)

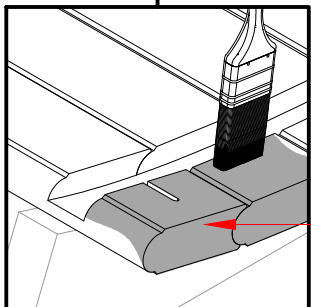

Add a layer of varnish*

C2:Varnish
(HELO AQUA 40)

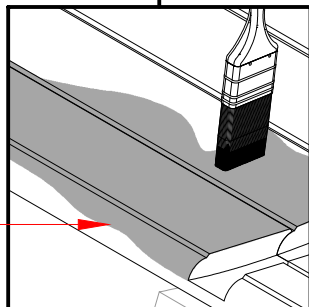

Add 1-2 coats of paint*

(First coats of paint **C3**,
Second coat of paint **C4**)

C3:Paint (Black)
(Teknos Aqua Primer)
C4:Paint (Black)
(Teknos Visa Base 3)

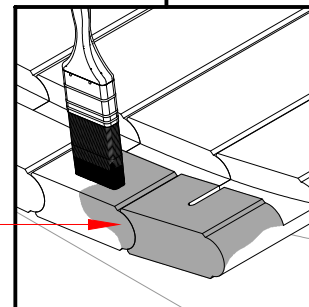

(HELO AQUA 40 IS FOR THE FLOOR ONLY)

Exterior construction (Floor construction and preparation)

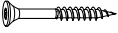
Screw(s)*	Name:	Quantity:
	S7	2

*Screw dimensions - exterior construction detail list

Lift the bottom of the sauna up on one side and install some aids!
 Clean the bottom surface!
 Cover the surface with paint or wood oil!**
 Install a piece of drain pipe V1!
 Install the rubber seal R1!
 Remove boards B2.1!

** Follow the manufacturer's instructions!

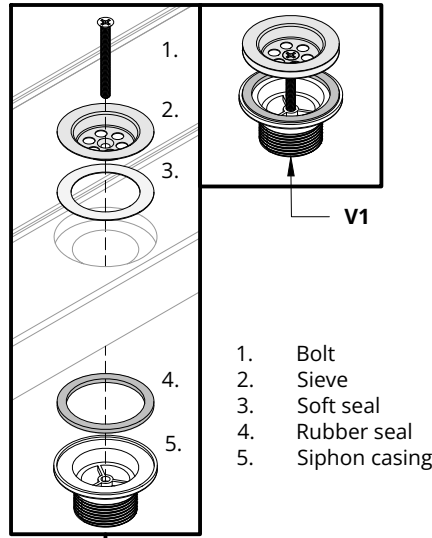

1. Bolt
2. Sieve
3. Soft seal
4. Rubber seal
5. Siphon casing

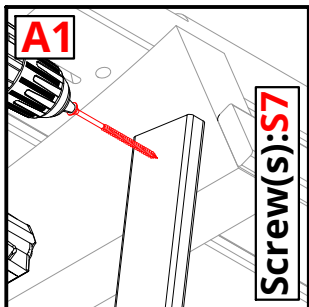
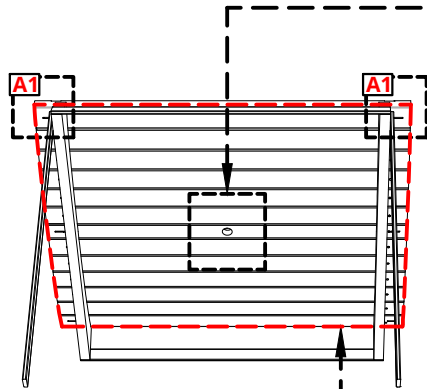

Screw(s): S7

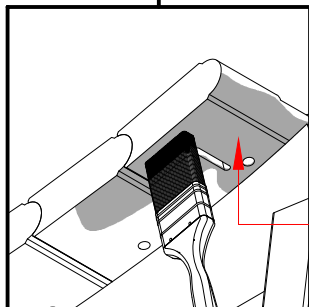

Add 1-2 coats of paint**

(First coats of paint C3, Second coat of paint C4)

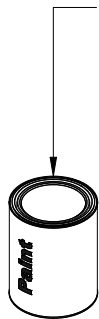

C3: Paint (Black)

(Teknos Aqua Primer)

C4: Paint (Black)

(Teknos Visa Base 3)

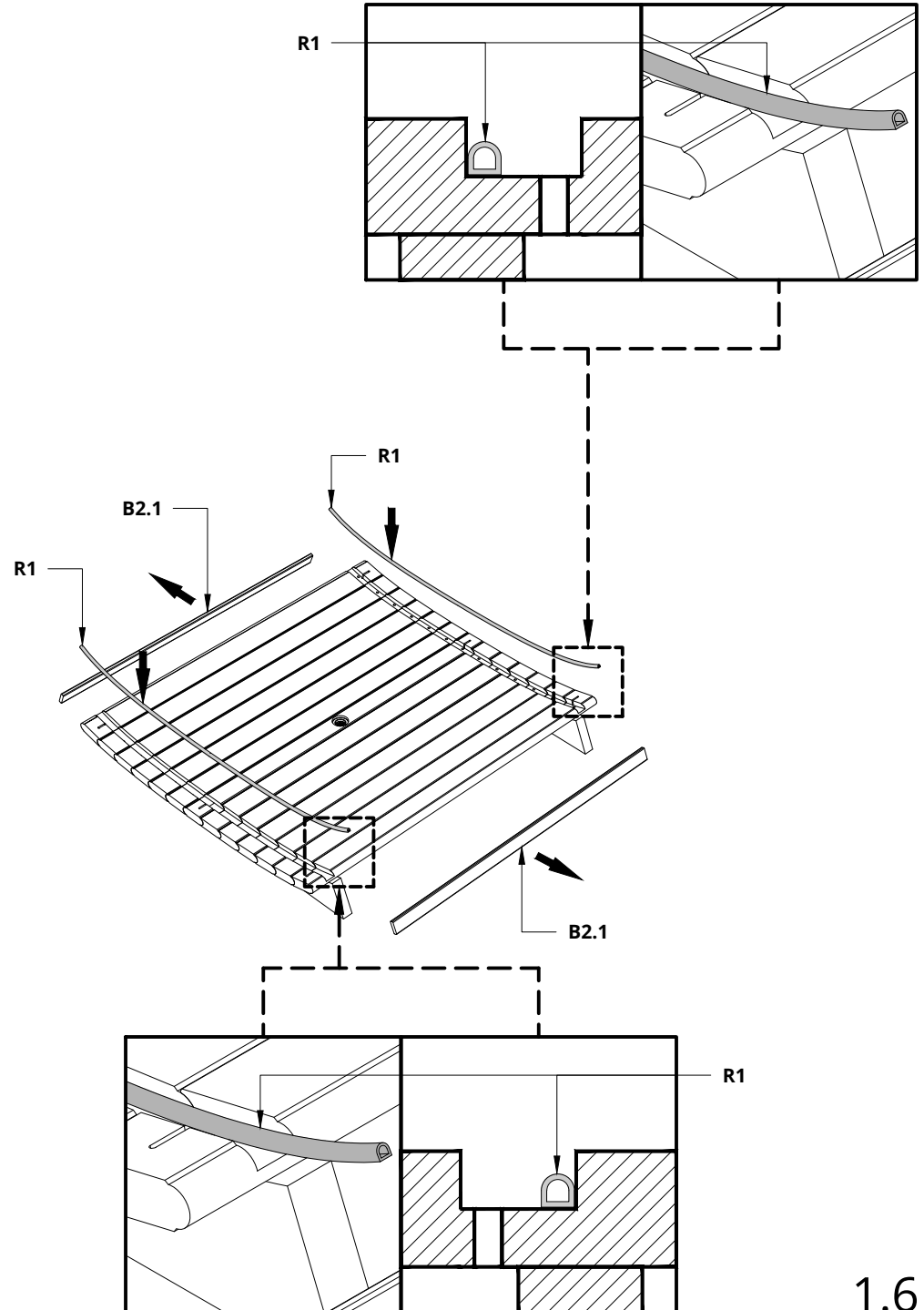

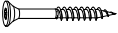
Screw(s)*	Name:	Quantity:
	S7	4
	S5	4

*Screw dimensions - exterior construction detail list

Please countersink the screw head(s)!
Assemble and prepare of the front wall!
Fasten the parts with screws and jigs!
Clean the edge and the outer surface of the front wall from wood waste and other dirt!
Varnish the edge of the wall from the bottom to middle!**
Cover the wall outer surface with paint!**
 ** Follow the manufacturer's instructions!

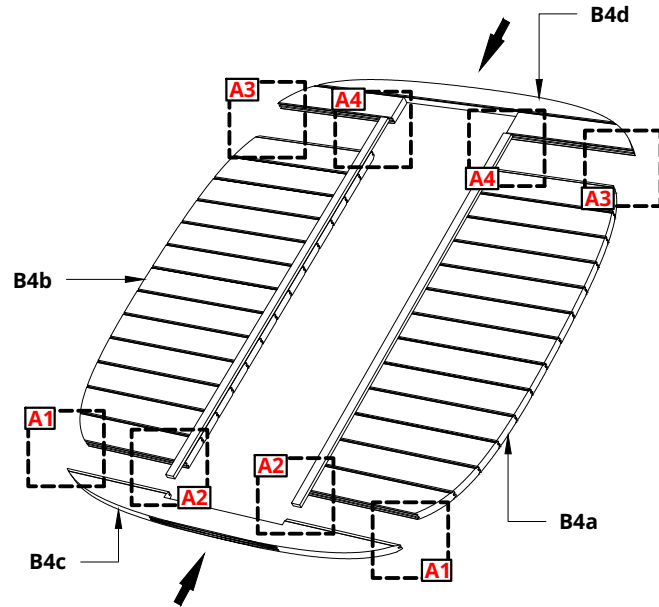
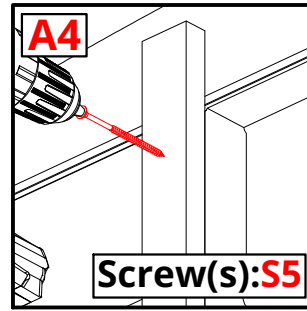
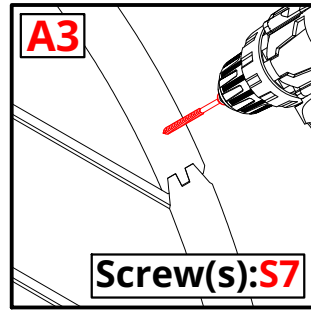

C3: Paint (Black)
 (Teknos Aqua Primer)
C4: Paint (Black)
 (Teknos Visa Base 3)

Add 1-2 coats of paint**
 (First coats of paint **C3**,
 Second coat of paint **C4**)

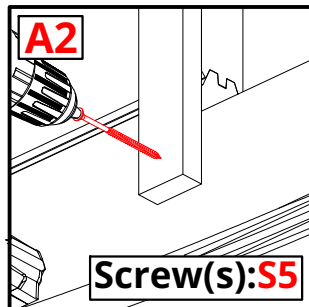
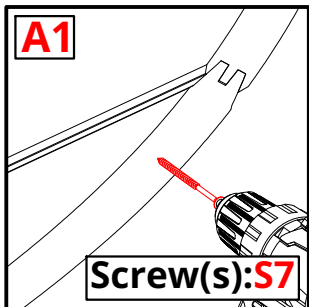
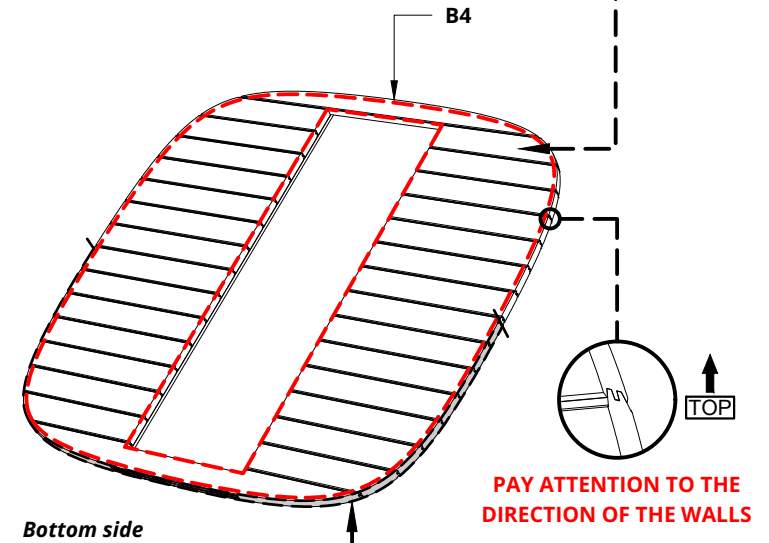
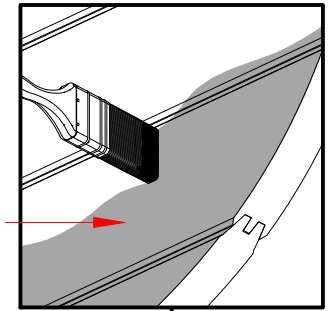

Add 2 coats of varnish**

C1: Varnish
 (INARIJÄRVI)

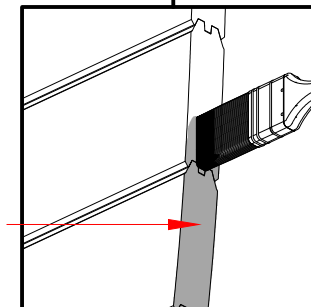

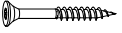
Screw(s)*	Name:	Quantity:
	S5	12

*Screw dimensions - exterior construction detail list

Only necessary for a glass wall version!
Please countersink the screw head(s)!
Assemble and prepare of the front wall!
Remove the door moldings (B7a)!
Use glue between the B4a and B4b!
Fasten the parts with screws and jigs!
Let the glue dry!
Clean the edge of the wall from wood waste and other dirt!
Varnish the edge of the wall from the bottom to middle!**

** Follow the manufacturer's instructions!

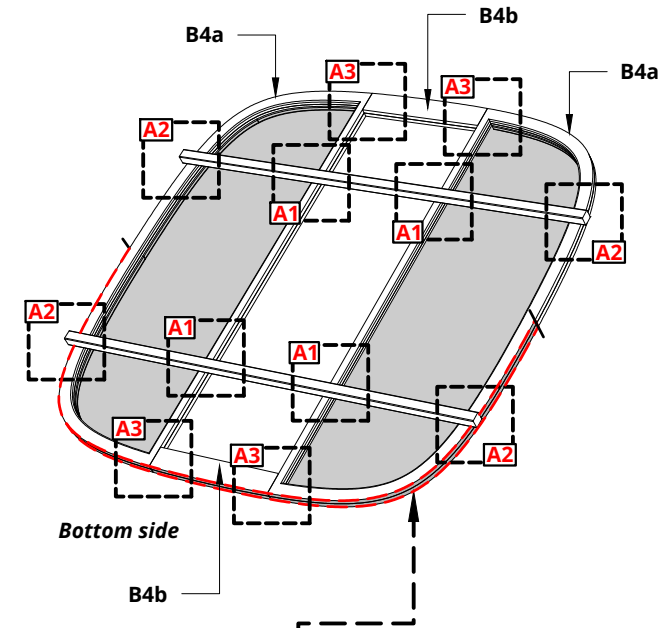
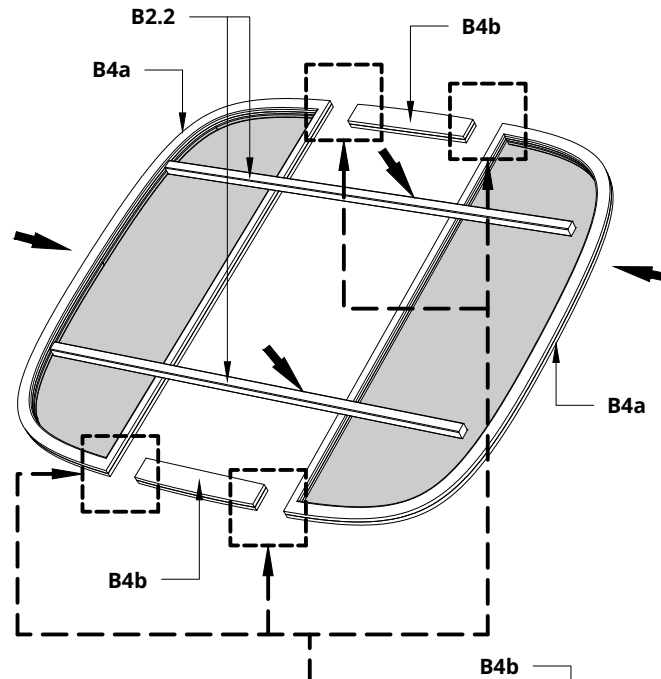
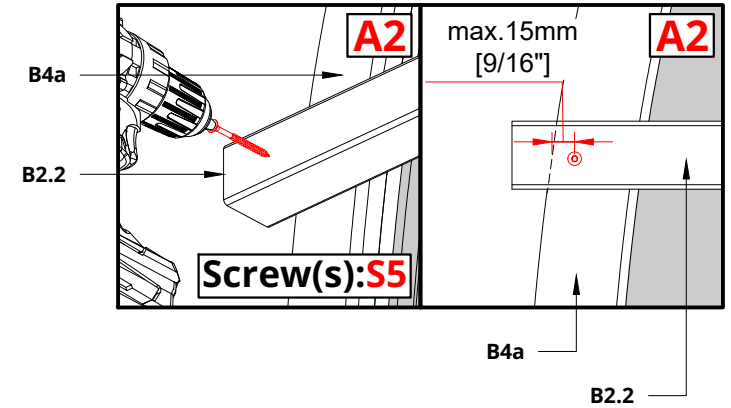
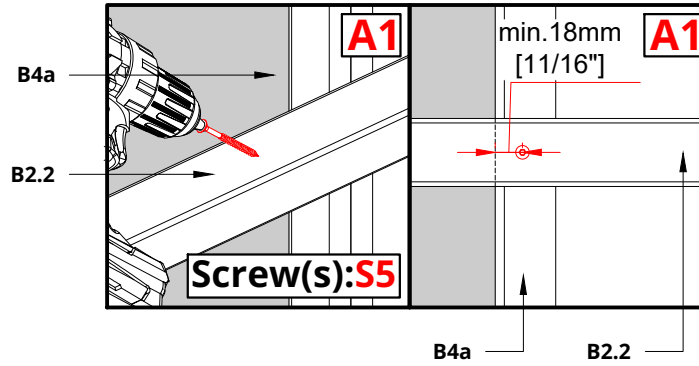

Remove the door molding (B7a) from both B4a. Fixed with 5 screws.

Remove the door molding (B7a) from both B4a. Fixed with 5 screws

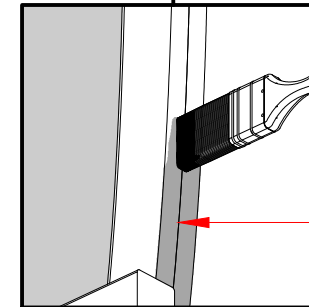
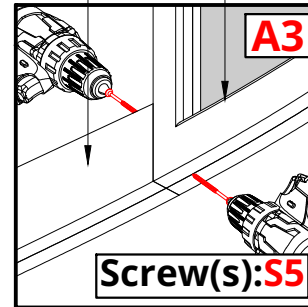
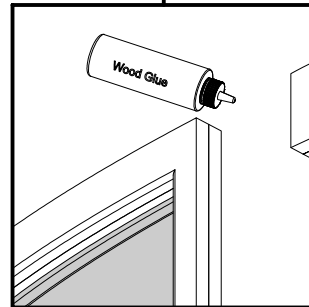
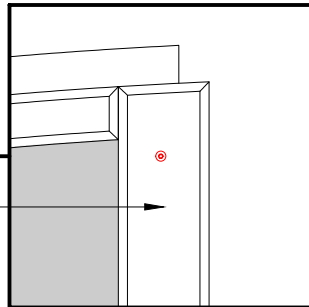

Add 2 coats of varnish**



C3: Paint (Black)
(Teknos Aqua Primer)
C4: Paint (Black)
(Teknos Visa Base 3)

Add 1-2 coats of paint*
(First coats of paint **C3**,
Second coat of paint **C4**)

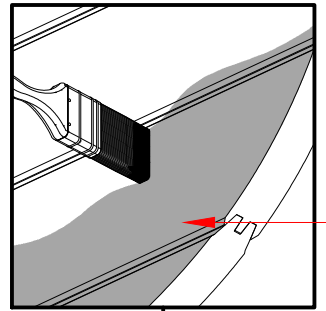
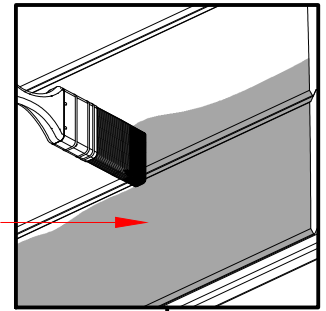

C3: Paint (Black)
(Teknos Aqua Primer)
C4: Paint (Black)
(Teknos Visa Base 3)

Add 1-2 coats of paint*
(First coats of paint **C3**,
Second coat of paint **C4**)

Preparation of the back wall(s)!
Clean the edge of the lower part of the back wall and the outer surface from wood waste and other dirt!
Varnish the lower edge of the back wall from the bottom to middle!*
Cover the lower part (and upper part**) of the back wall outer surface with paint!*

* Follow the manufacturer's instructions!
** Only on the wooden back wall

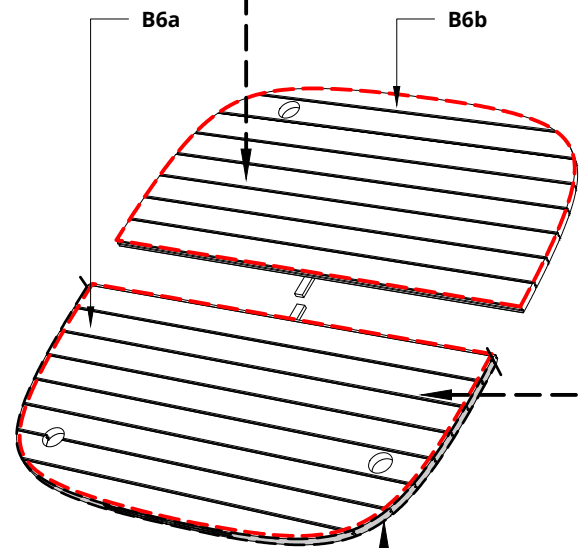

Wooden back wall (lower and upper part)

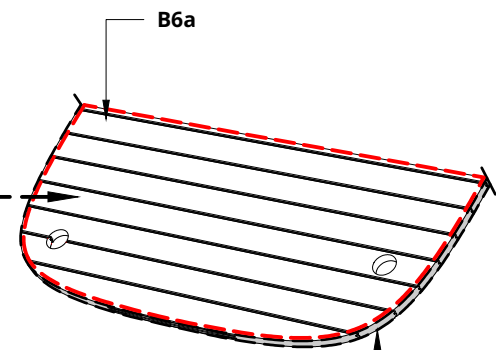

Half panoramic back wall (lower part)

Add 2 coats of varnish*

C1: Varnish (INARIJÄRVI)

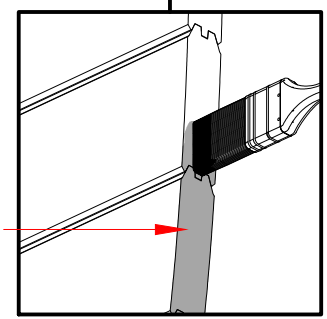

Add 2 coats of varnish*

C1: Varnish (INARIJÄRVI)

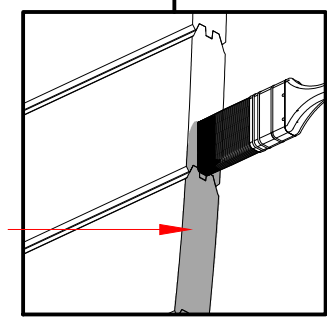

Preparation for side wall boards.

Before doing the processes, clean the sidewall boards from wood waste and other dirt!

* Follow the manufacturer's instructions!

Boards	First ones			The following ones			
	B3a	B3b	B3c	B3a	B3b	B3a	B3b
Process 1	✓	✓	✓	✗	✗	✗	✗
Process 2	✓	✓	✓	✓	✓	✓	✓
Process 3	✓	✓	✓	✓	✓	✗	✗
Label them as	1L	1R	1.1R	2L	2R	3L	3R
Quantity	5	4	1	8	8	19	19

Add 1-2 coats of paint*

(First coats of paint C3, Second coat of paint C4)

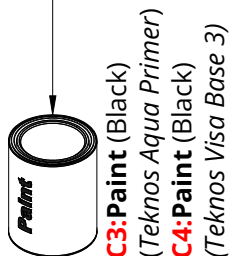

Add 1-2 coats of paint*

(First coats of paint C3, Second coat of paint C4)

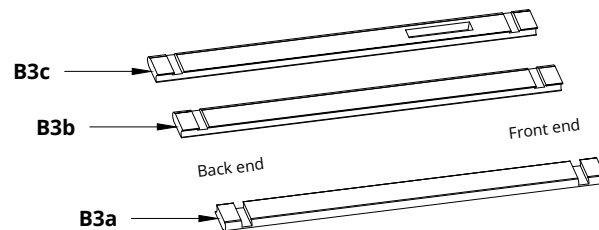
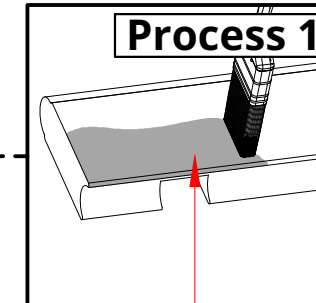
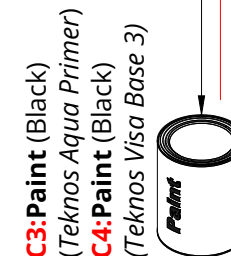

Side without grooves



Back end

Front end

Side of the board with front and back wall grooves

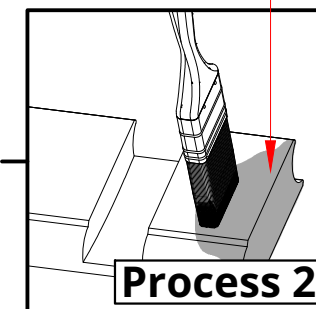
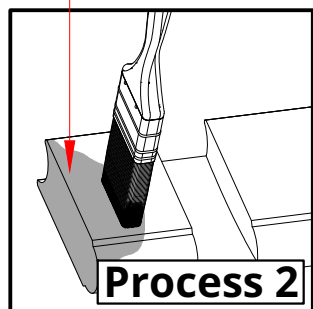

Add 2 coats of varnish*



Add 2 coats of varnish*

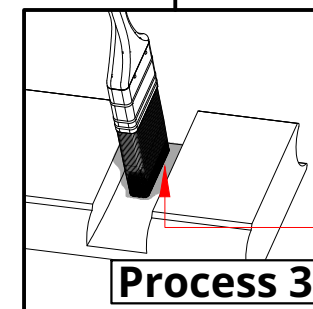
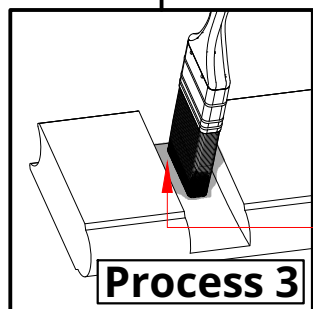

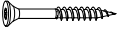
Screw(s)*	Name:	Quantity:
	S5	8

*Screw dimensions - exterior construction detail list

NB! use a level



The same steps apply to the bottom part of the panoramic back wall

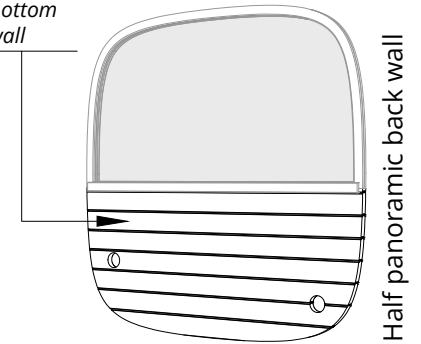

Half panoramic back wall

Please countersink the screw head(s)!
Make sure that the walls are centered in relation to the bottom!
Install safety boards on walls, use boards B3a and B3b, that are labeled as 3L and 3R!
Remove the back wall connection strip(s)!
*** Depends on the choice of sauna wall!*

PAY ATTENTION TO THE DIRECTION OF THE WALLS!

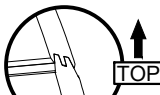

B4 depends on the choice of sauna front walls

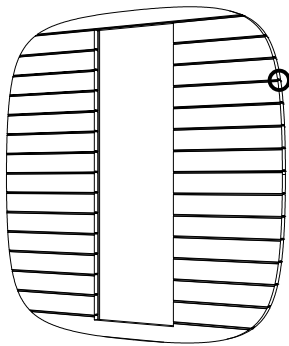

Wooden front wall

OR

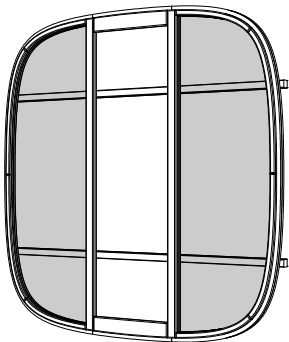

Glass front wall

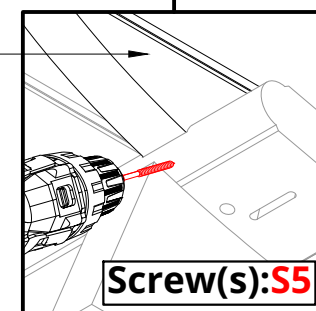
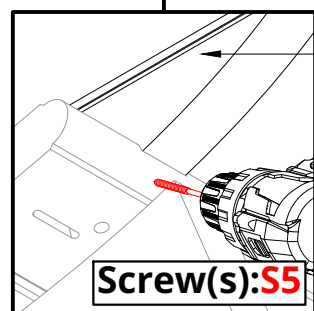
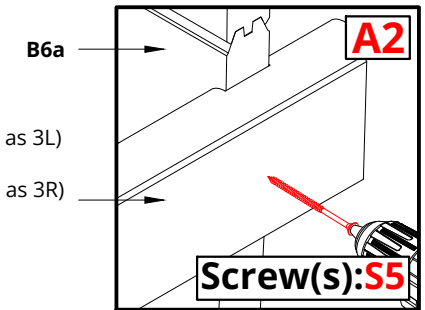
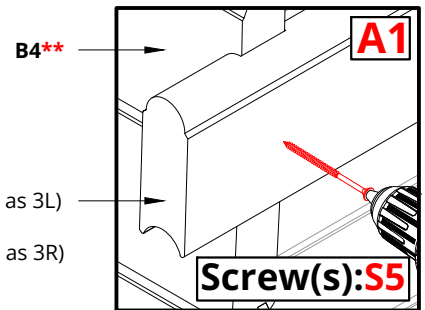
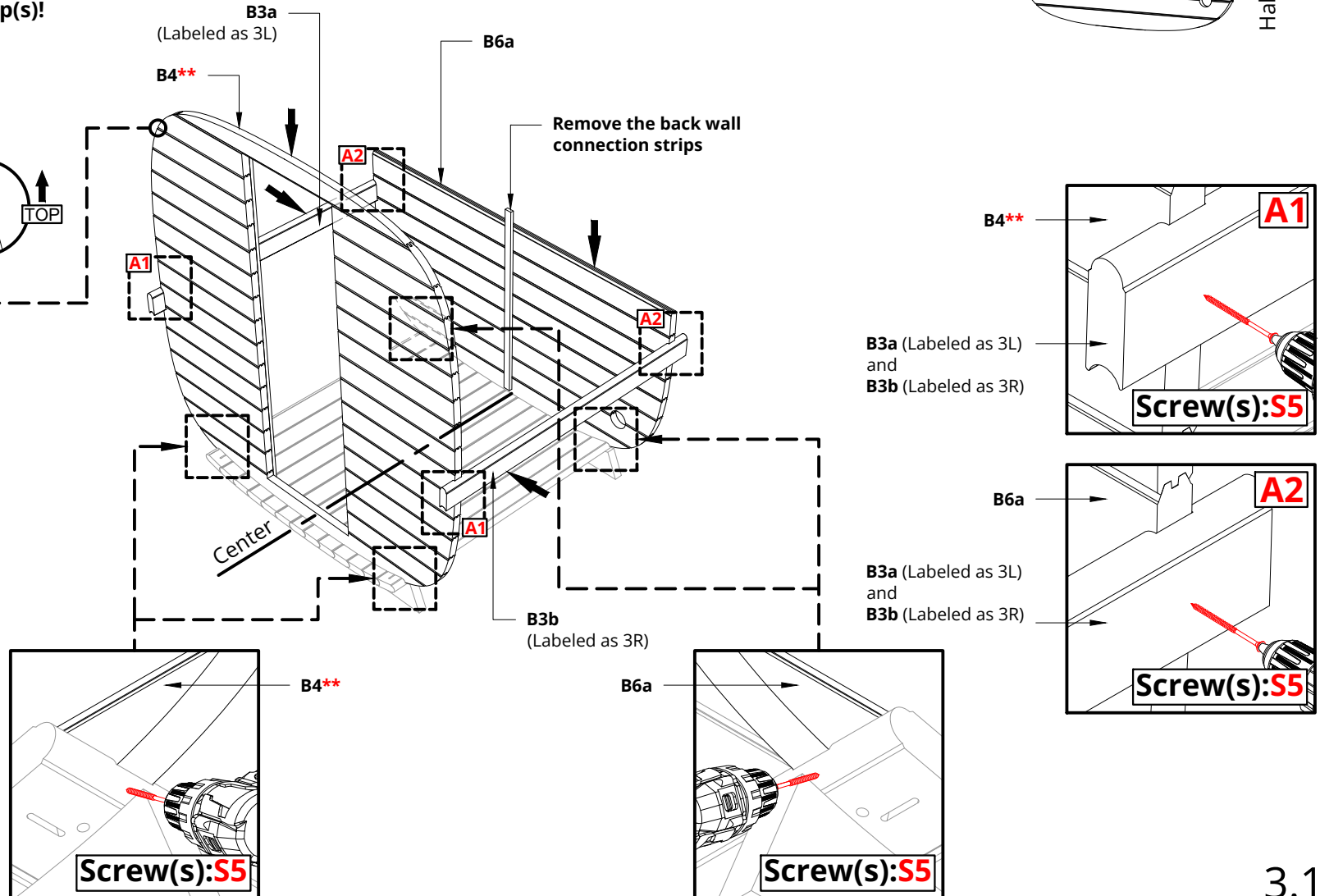

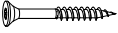
Screw(s)*	Name:	Quantity:
	S7	2
	S5	4

*Screw dimensions - exterior construction detail list

Please countersink the screw head(s)!
Install the upper part of the back wall B6b and the upper safety board(s)!
Remove the back wall connection strip(s)!
Panorama construction instructions are on the next page!

** Depends on the choice of sauna wall!

B4 depends on the choice of sauna front walls

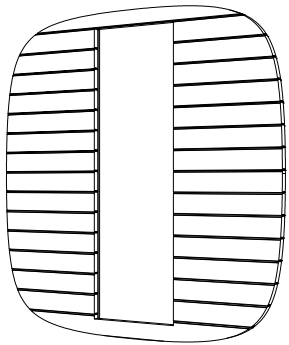

Wooden front wall

OR

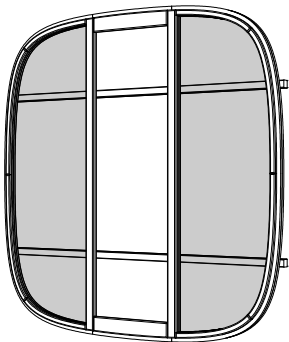

Glass front wall

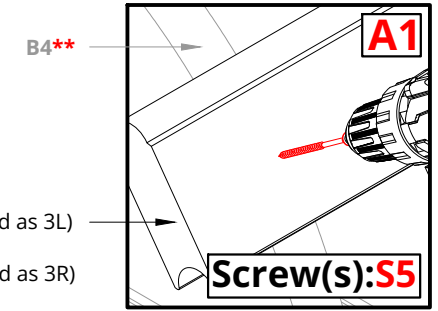
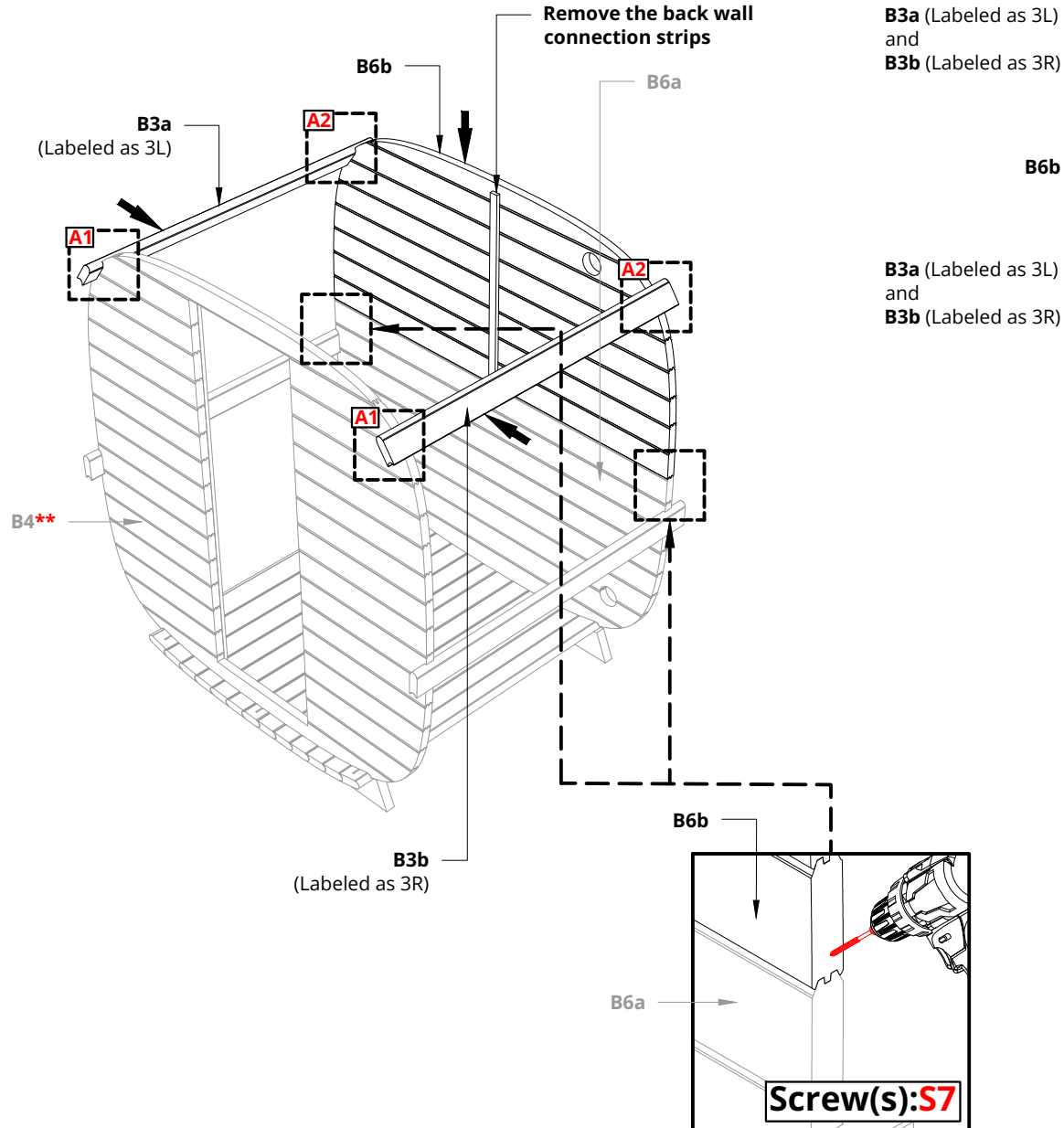

B3a (Labeled as 3L) and B3b (Labeled as 3R)

Screw(s):S5

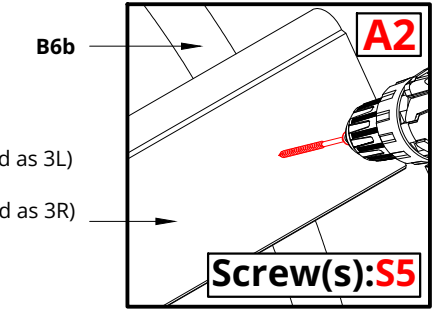

B3a (Labeled as 3L) and B3b (Labeled as 3R)

Screw(s):S5

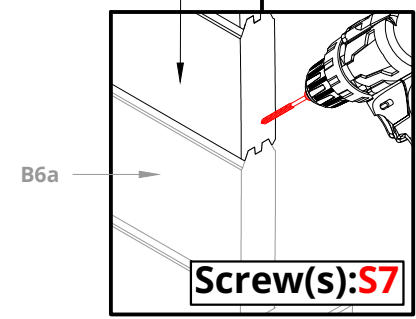

Screw(s):S7

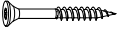
Screw(s)*	Name:	Quantity:
	S7	2
	S5	4
	S2	5

NB! use a level

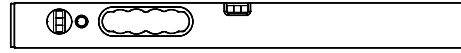

*Screw dimensions - exterior construction detail list

Only necessary for a panorama back wall version!
Install the upper part of the back wall B6b and the upper safety board(s)!
Install a panoramic wall molding!
**** Depends on the choice of sauna wall!**

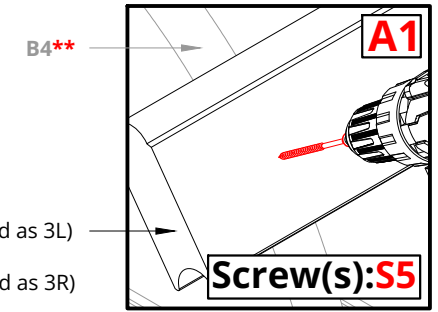

B3a (Labeled as 3L) and B3b (Labeled as 3R)

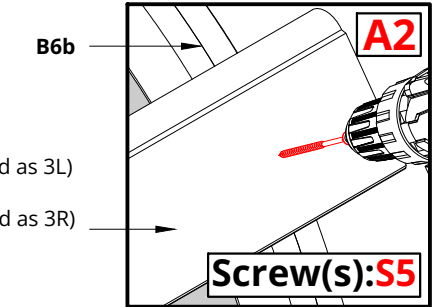

B3a (Labeled as 3L) and B3b (Labeled as 3R)

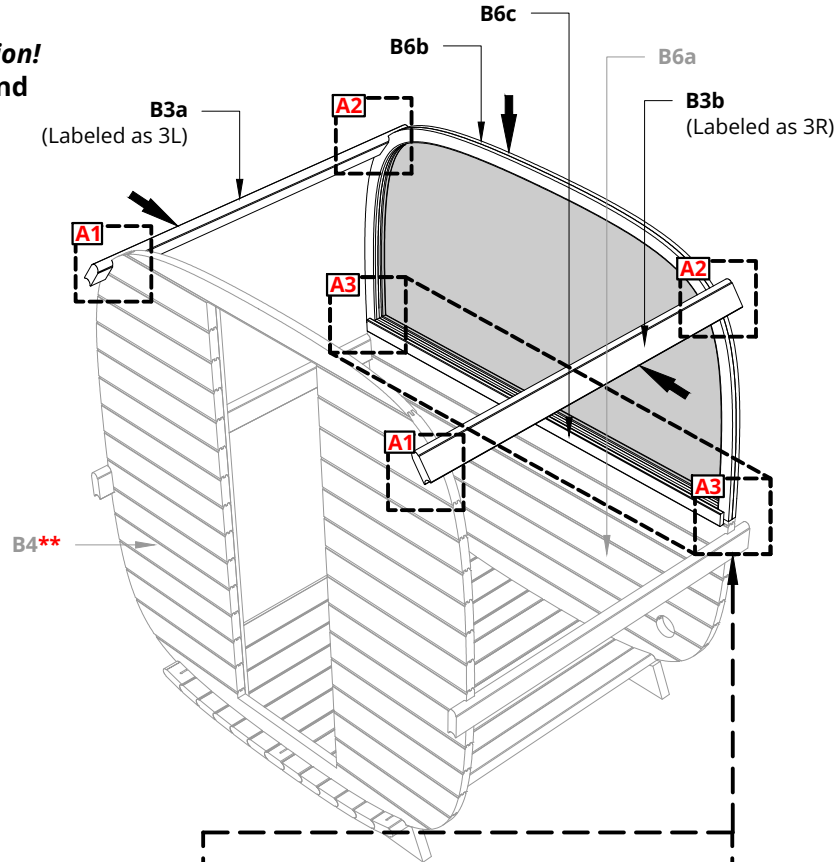

B4 depends on the choice of sauna front walls

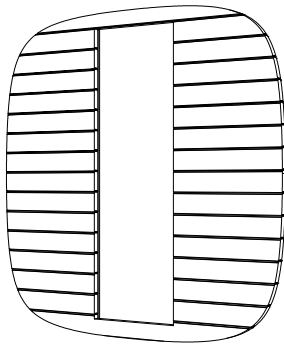

Wooden front wall

OR

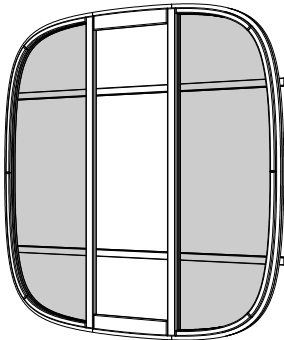

Glass front wall

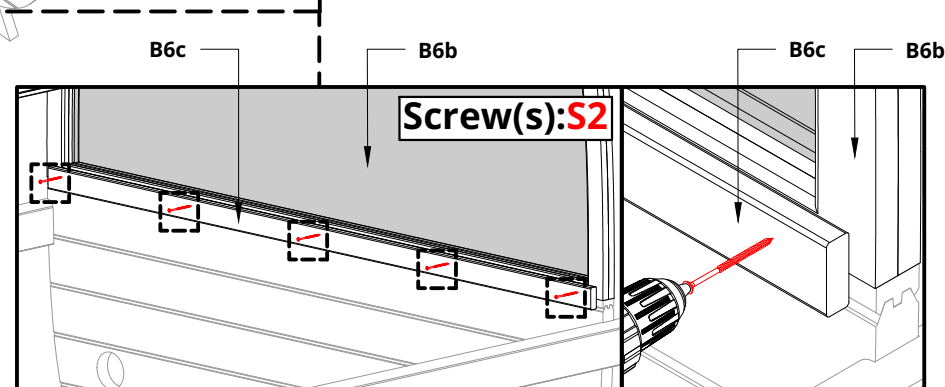
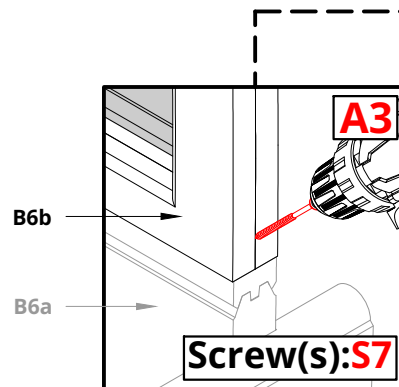

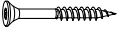
Screw(s)*	Name:	Quantity:
	S5	104

*Screw dimensions - exterior construction detail list

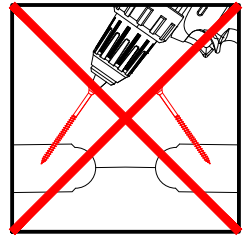

Please countersink the screw head(s)!
Use a rubber mallet to tap the boards into place!

Please do not screw the screws in on the last whole boards immediately!

** Depends on the choice of sauna wall!

*** For glass wall only!

B4 depends on the choice of sauna front walls

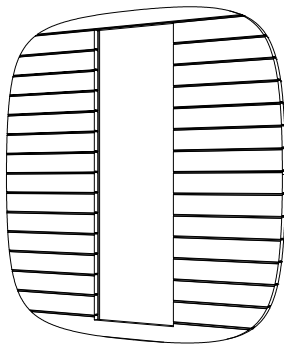

Wooden front wall

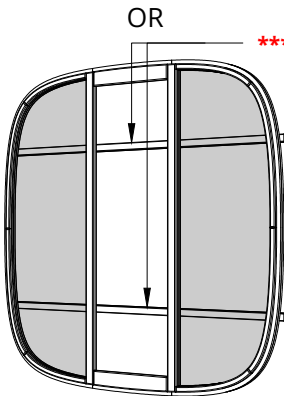

Glass front wall

*** If they start to interfere, they can be removed

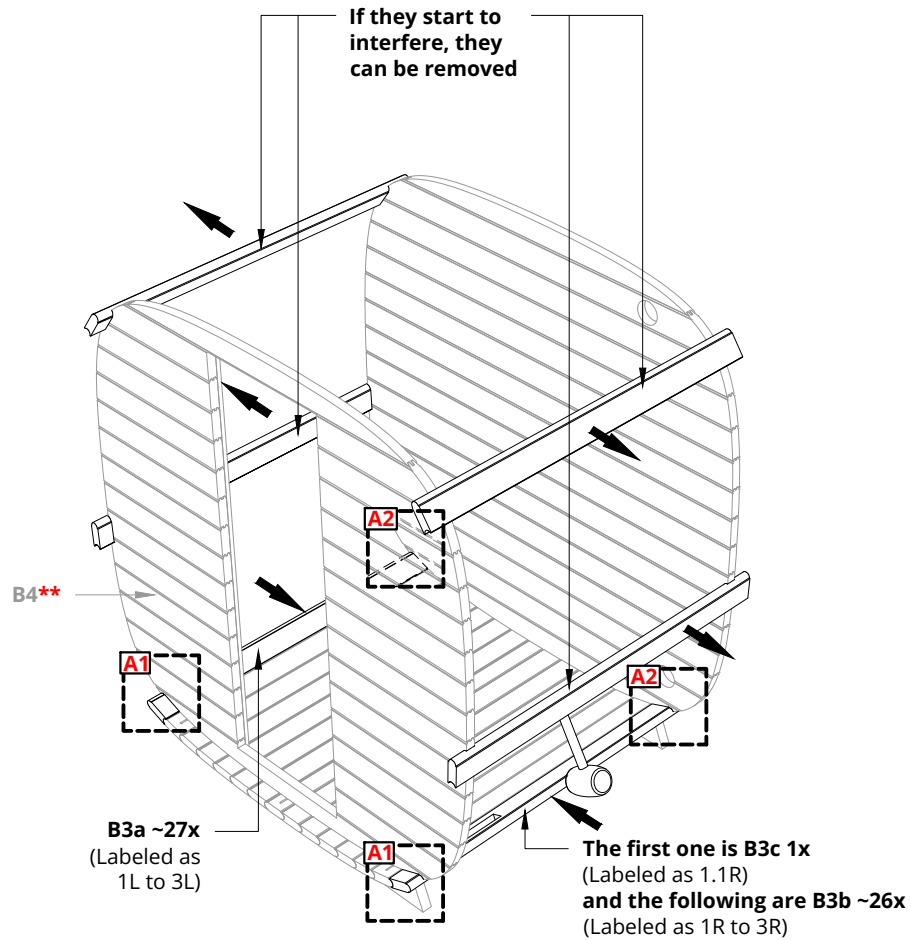

B3a left and B3b - B3c right
layout of labeled boards

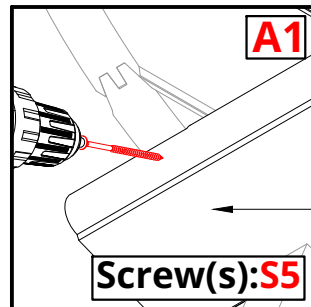
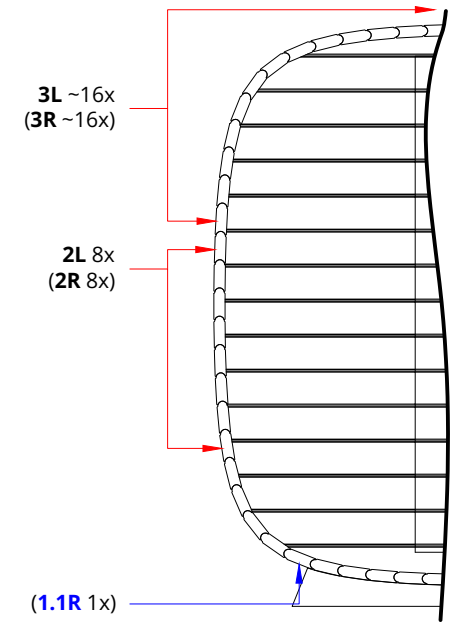

B3a left
(Labeled as 1L to 3L)
B3b and B3c right
(Labeled as 1.1R, 1R to 3R)

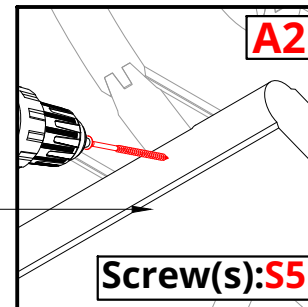

Measure the gap front and back, the dimensions can be different!

Divide the measurement by two and transfer the measurements to the last two boards. Connect the dimensions on the board with a line.

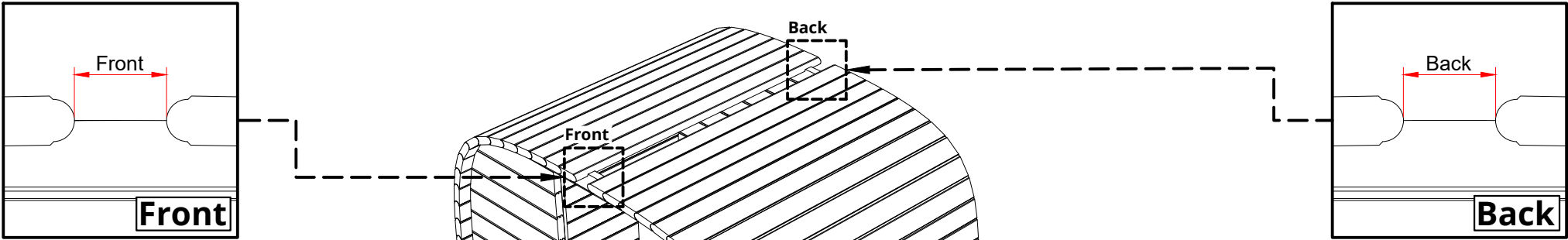

Front measurement.

Back measurement.

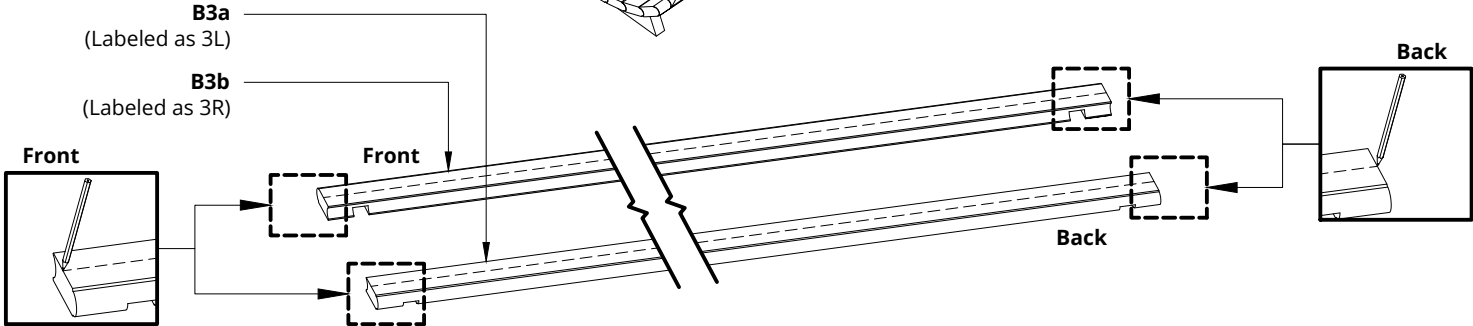
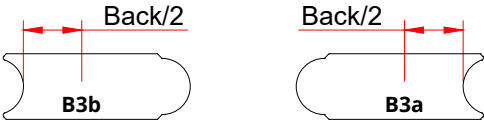
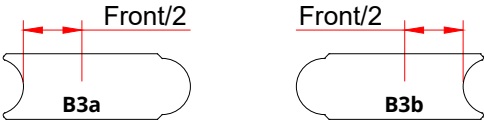

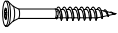
Screw(s)*	Name:	Quantity:
	S2...S7	5
	S5	6

*Screw dimensions - exterior construction detail list

Please countersink the screw head(s)!
Prepare the last board!
Use a rubber mallet to tap the boards in to the cap!

Cut along the marked line to cut off these ends. Glue the two cut boards with wood glue and connect them with 5 pieces of **S2...S7** screws (*the length of the screws depends on the final width of the last two planks cut*). Wipe off excess glue with a cloth and then use sandpaper to smooth out the gap.

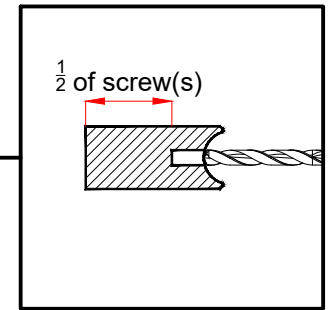
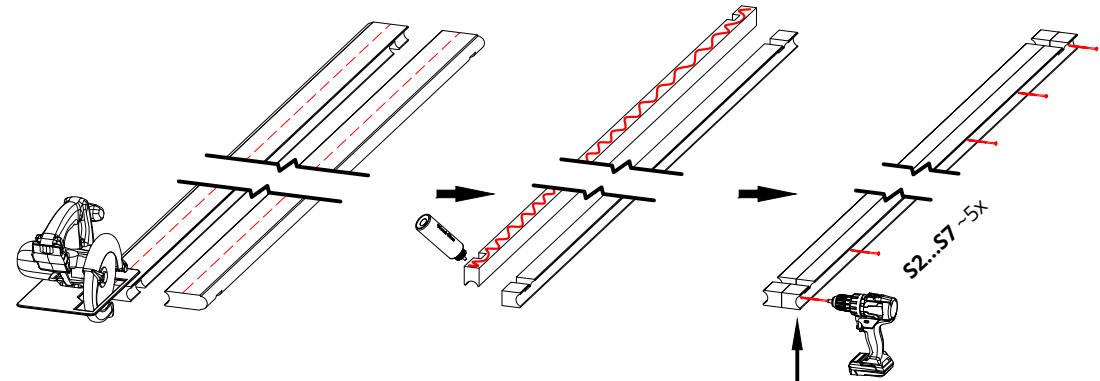

Suggestions!
 Drill pockets for screws if the screws do not extend through

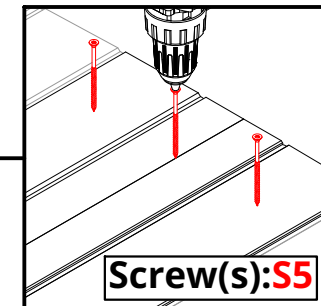
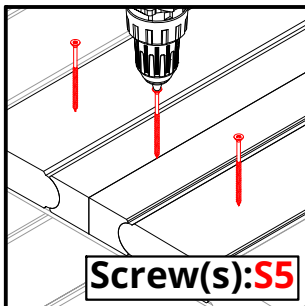
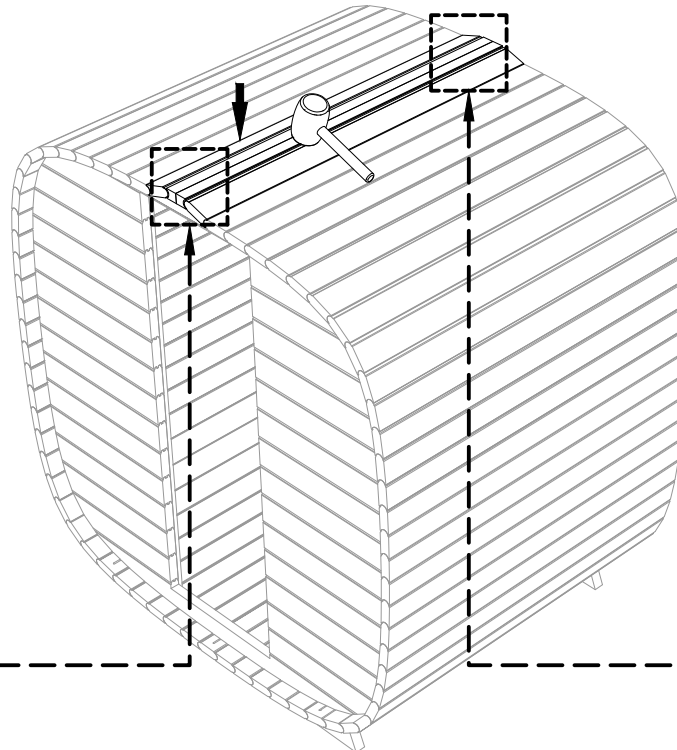

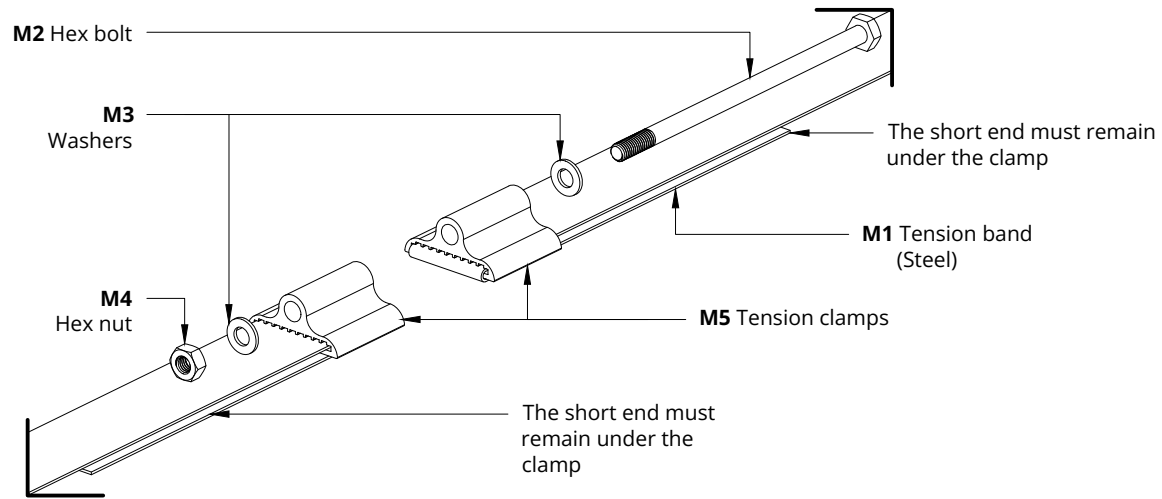

Place the tension bands M1 (Steel band(s)) around the side walls and thread the band(s) into the eyelet as follows (see sketch above).

Hex nuts and bolts must be tightened as long as the boards are stationary in all directions.

The tension band and clamps must be placed as shown in the picture below.

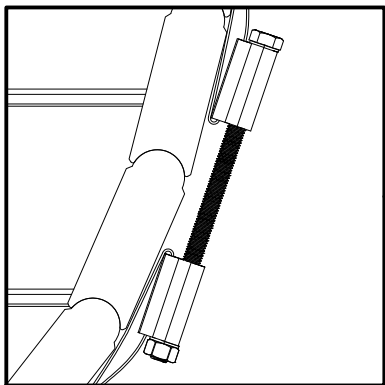
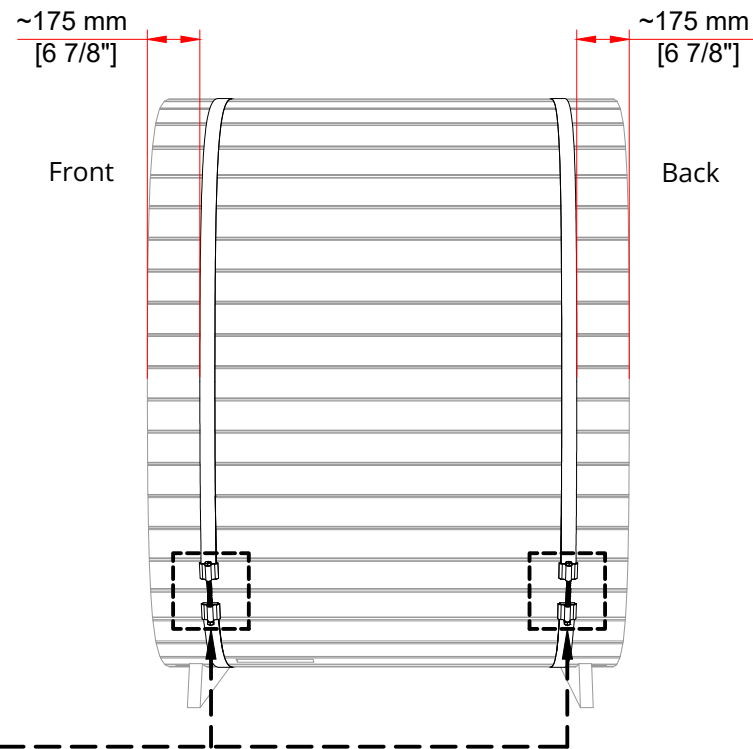

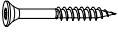
Screw(s)*	Name:	Quantity:
	S1	10

*Screw dimensions - exterior construction detail list

NB! use a level

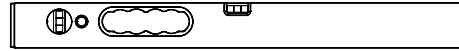

BLACK Cube Classic		
Min. height - a	~1195 mm	~ 3'-11 1/16"
Max. height - b	~1005 mm	~ 3'-3 9/16"

Please countersink the screw head(s)!
Height measurements are measured from a straight surface (ground) or from above the sauna!

Install the eaves edge (tin strip) on the left and right!

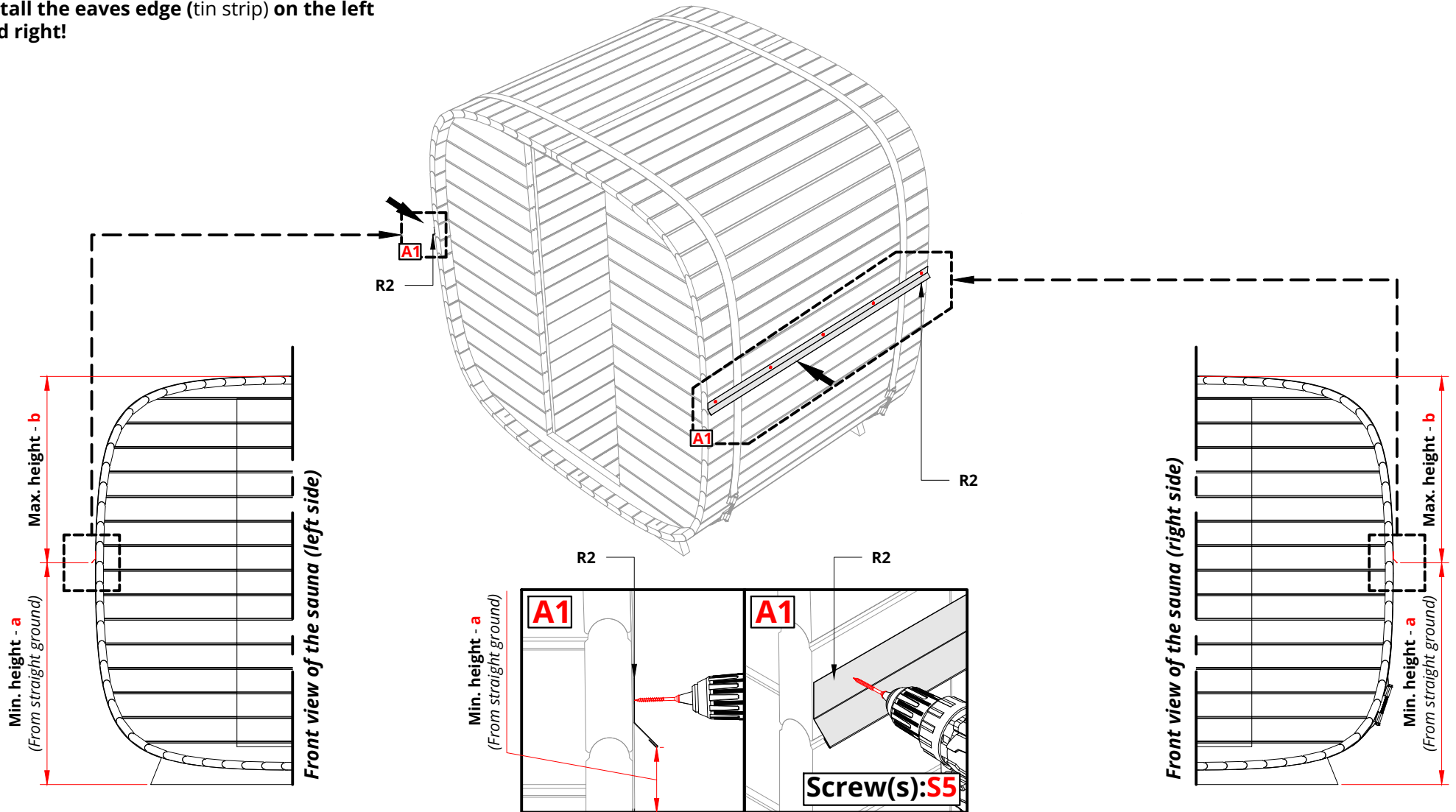

Nail(s)* 	Name: R6	Quantity: ~35
---	--------------------	-------------------------

*Nail dimensions - exterior construction detail list

Use a heat source when bending the underlay!

**Install the underlay in the center of the roof!
The underlay must extend over the front end and back end!**

Fasten the underlay along the long edges!

Use a heat source when bending the underlay front end and back end!

Fasten the underlay front end and back end!

Cut off the ends that extend over the edge!

BLACK Cube Classic		
max. A	35 mm	~ 0'-1 3/8"
min. B	190 mm	~ 0'-7 1/2"
C	25 mm	~ 0'-1"

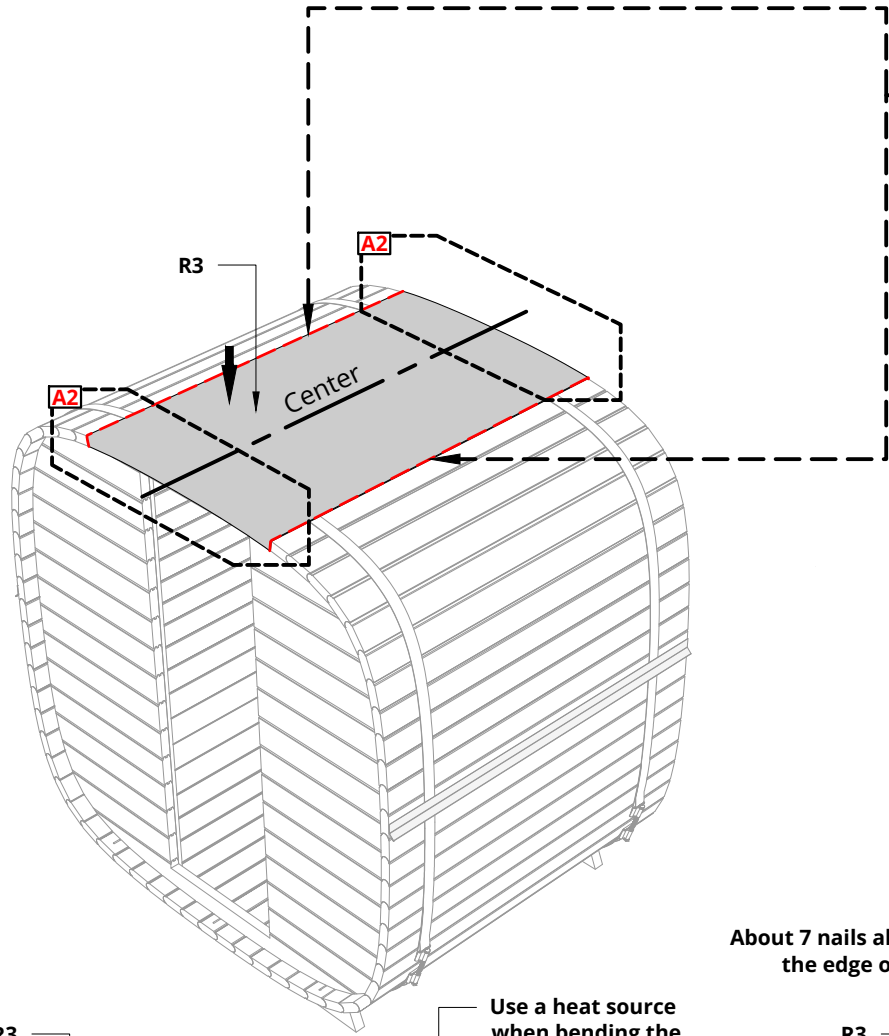

About 9 nails along the edge of R3

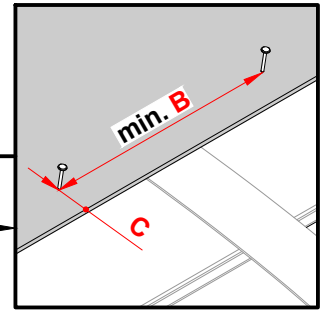

It is only necessary to cut if they extend over the edge!

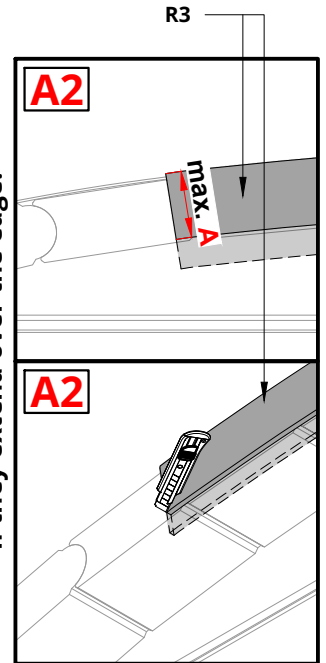

About 7 nails along the edge of R3

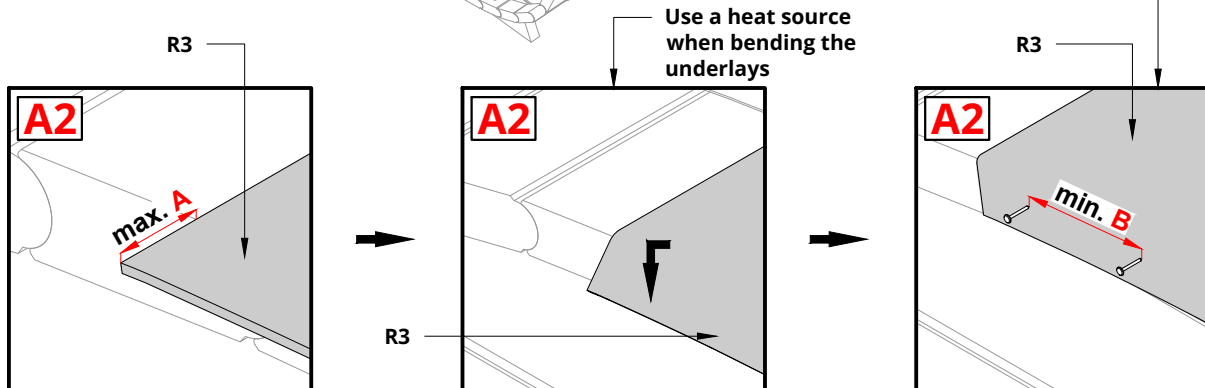

Katepal 3T Rectangle bitumen roof sheet row arrangement for Barrel Saunas.

The base row is installed first, then the first row, etc. up in the middle of the sauna. The sheets that remain over the edge of the sauna wall are cut off and, if possible, used for other rows.

The base row starts at the front end of the sauna, row 1 always starts offset from the front end.

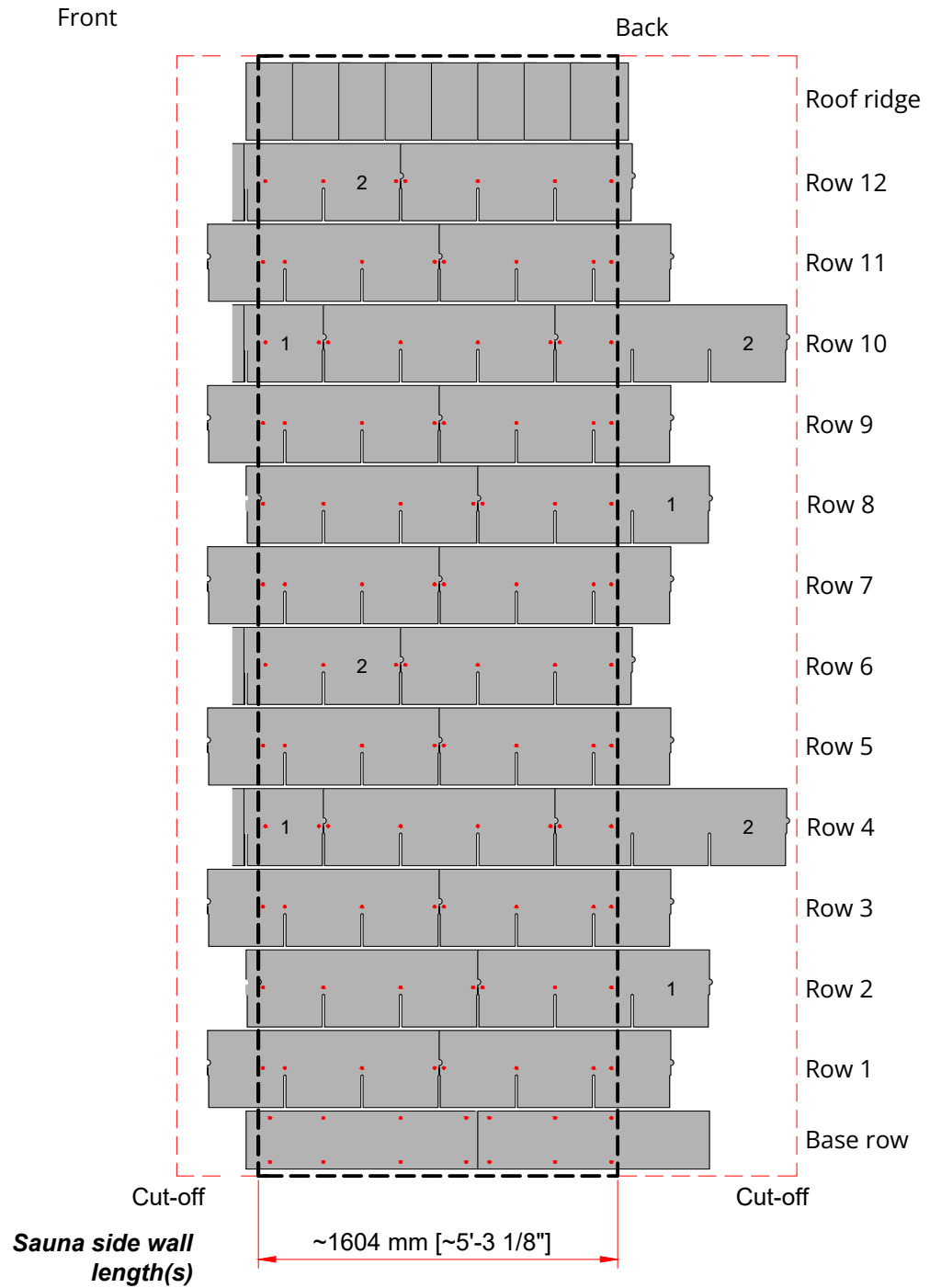
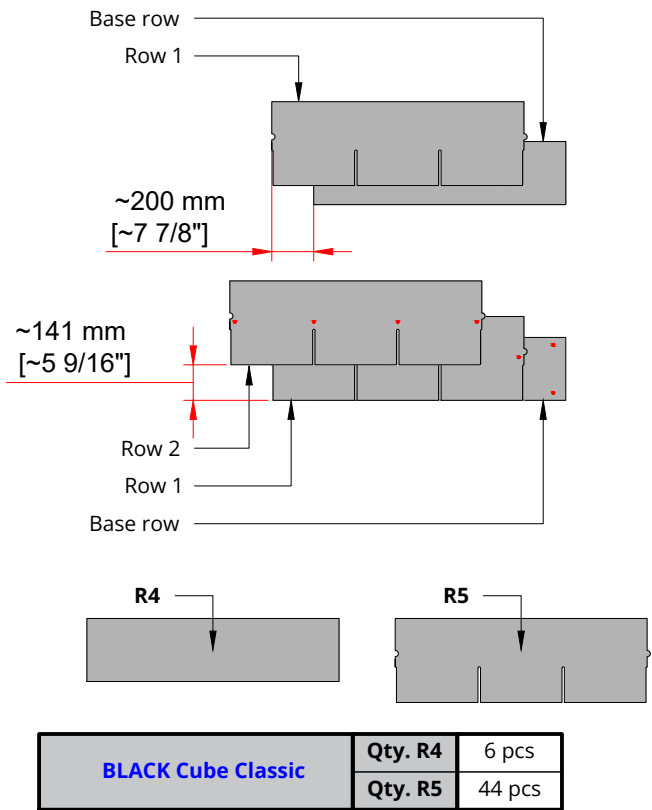

Nail(s)* 	Name:	Quantity:
	R6	~30

*Nail dimensions - exterior construction detail list

Sheets are self-adhesive, for better adhesion use a heat source!

The base row starts from the front!
Cut sheets that extend over the edge! (It is only necessary to cut if they extend over the edge!)
Suitable leftovers can be used!
Repeat these steps on the other side as well!

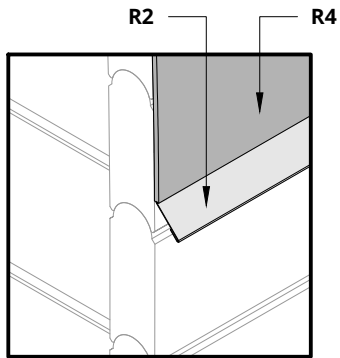

a	190 mm	~ 0'-7 1/2"
b	50 mm	~ 0'-1 15/16"
c	~283 mm	~ 0'-11 1/8"
d	~333 mm	~ 1'-1 1/8"
e	30 mm	~ 0'-1 3/16"

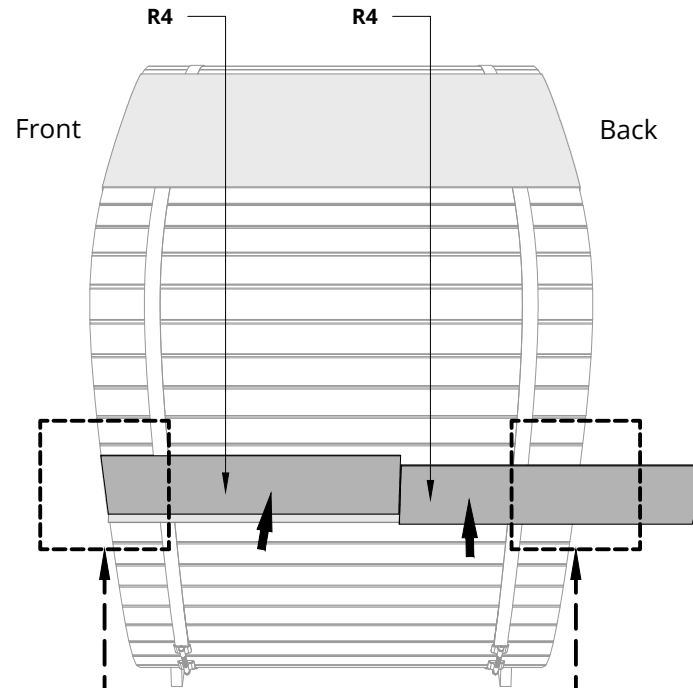
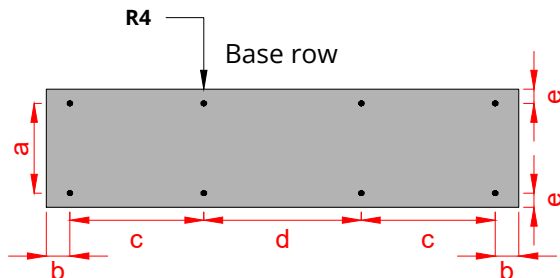

It is only necessary to cut if they extend over the edge!

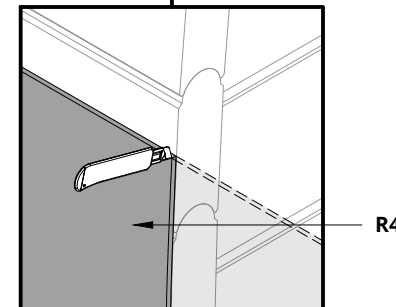
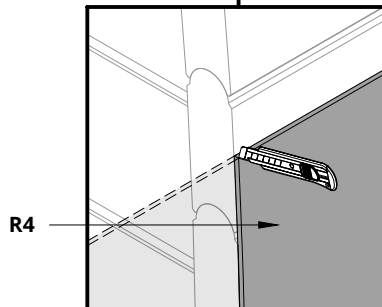

Nail(s)* 	Name:	Quantity:
	R6	~190

*Nail dimensions - exterior construction detail list

Sheets are self-adhesive, for better adhesion use a heat source!

**The 1. row starts at the front and offset!
Cut sheets that extend over the edge!
Suitable leftovers can be used!
Repeat these steps on the other side as well!**

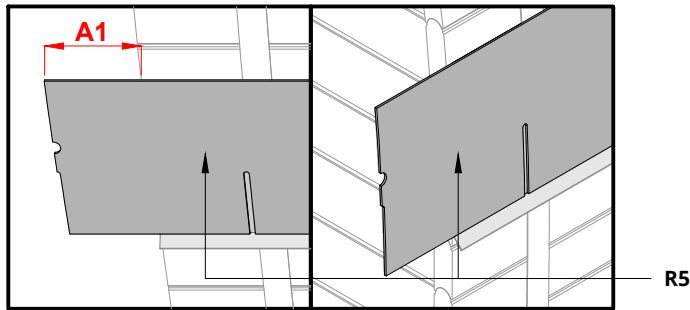

A1	~200 mm	~ 0'-7 7/8"
a	162 mm	~ 0'-6 3/8"
b	171 mm	~ 0'-6 3/4"
c	~313 mm	~ 1'-0 5/16"
d	~333 mm	~ 1'-1 1/8"
e	20 mm	~ 0'-0 13/16"

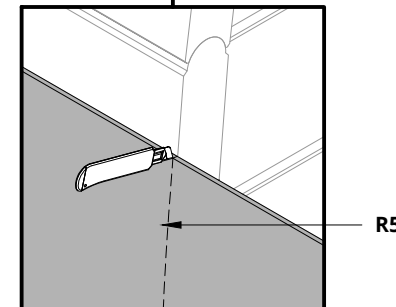
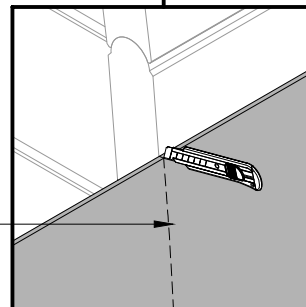
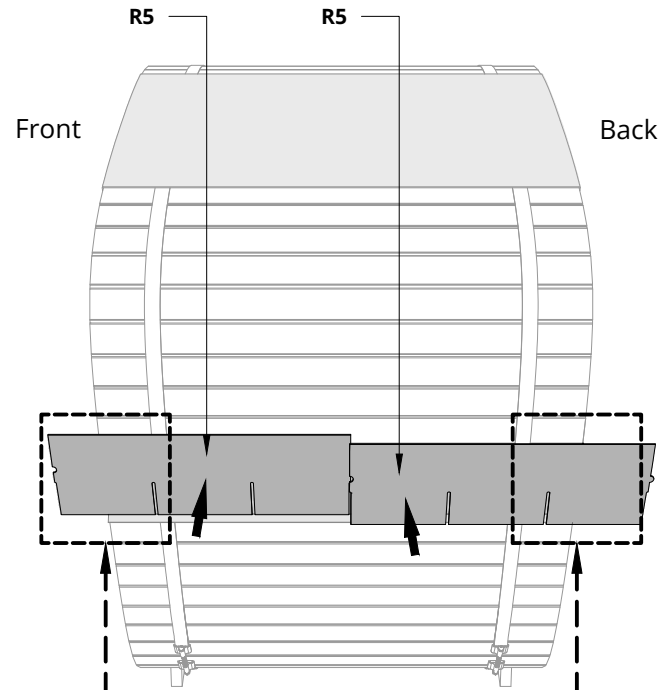
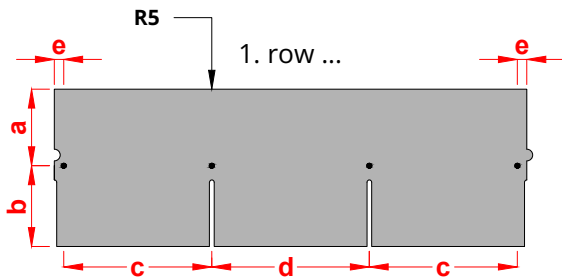

Nail(s)* 	Name:	Quantity:
	R6	~30

*Nail dimensions - exterior construction detail list

Sheets are self-adhesive, for better adhesion use a heat source!

The roof ridge can be started from the back end of the sauna or from the front end!

Cut sheets that extend over the edge!

On the last piece, use bitumen sealant, not nails!

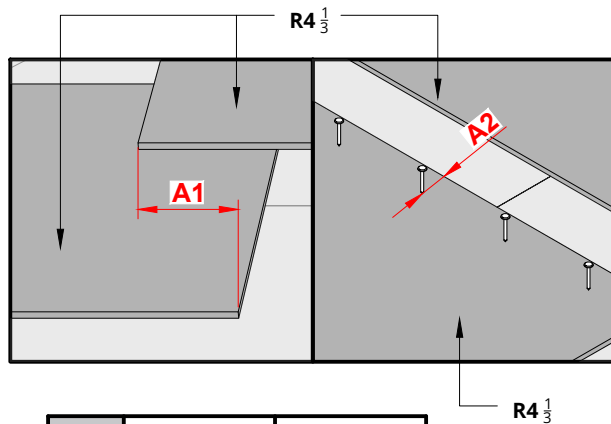

A1	~50 mm	~ 0'-1 15/16"
A2	25 mm	~ 0'-1"
a	~333 mm	~ 1'-1 1/8"

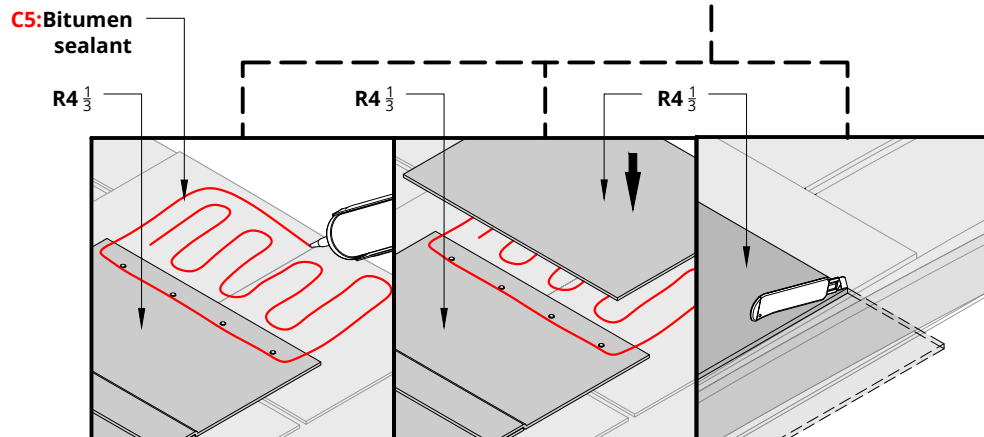
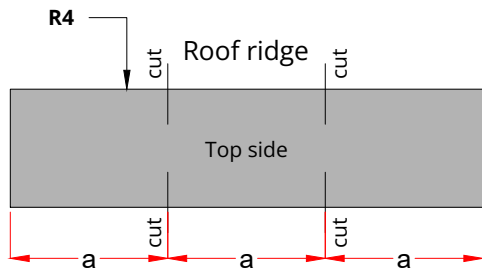
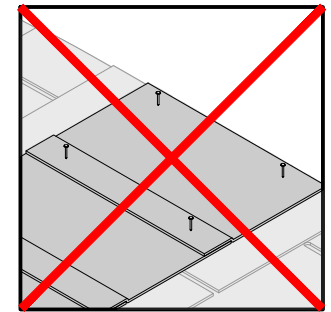
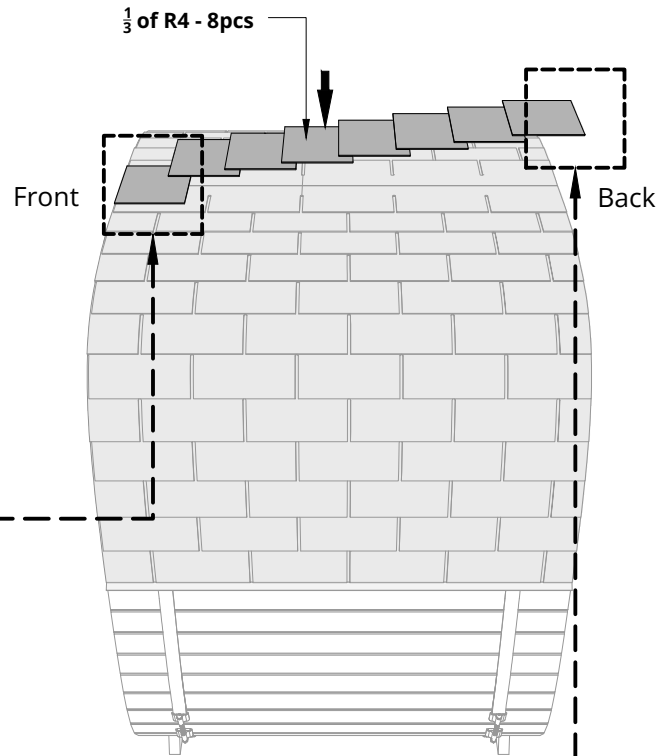

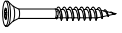
Screw(s)*	Name:	Quantity:
	S6.1	48

*Screw dimensions - exterior construction detail list

Please countersink the screw head(s)!
Install the cover boards R8, starting from the bottom!

Attach 8 cover boards at the front and back of the sauna!

Fix each with 3 screws!

Fill the gaps between the bitumen sheets and covering boards in front and back with bitumen sealant!

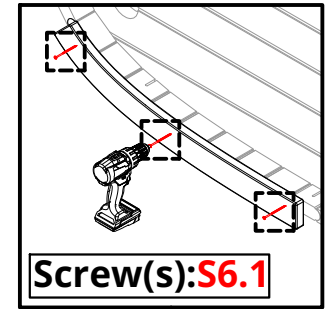
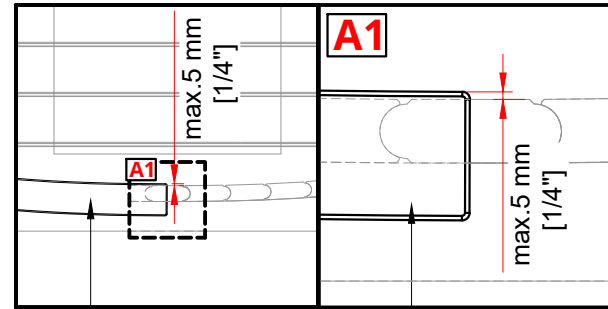
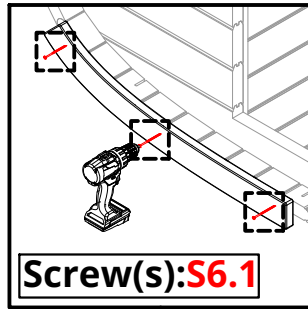

R8

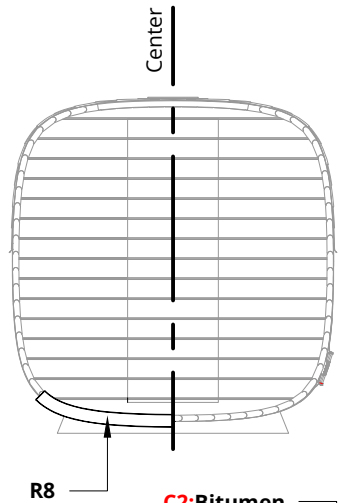

C2:Bitumen sealant

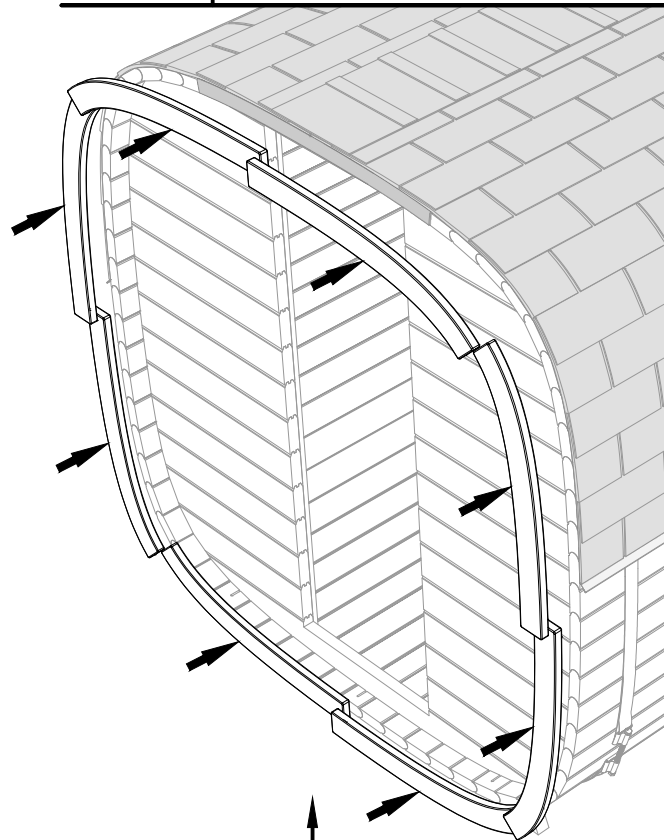
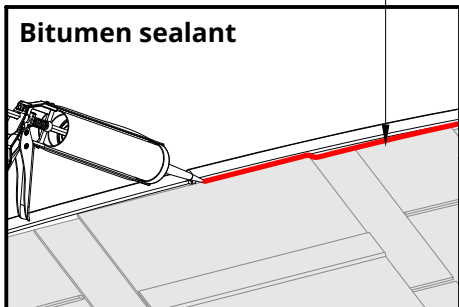

Front view of the sauna

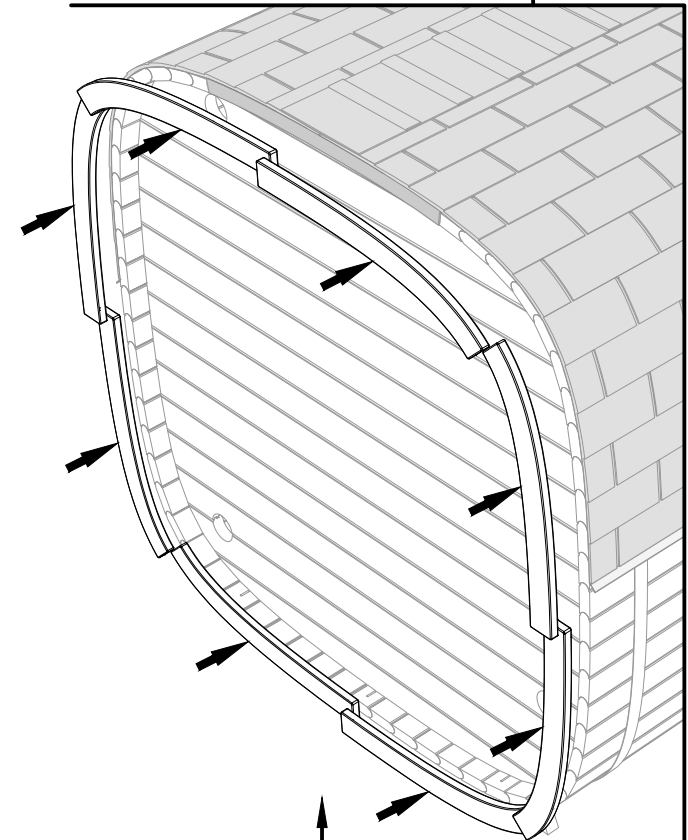

Back view of the sauna

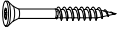
Screw(s)*	Name:	Quantity:
	S1	26

*Screw dimensions - exterior construction detail list

Install The inner and outer ventilation grilles V2, adjustable cover V3 and V4!

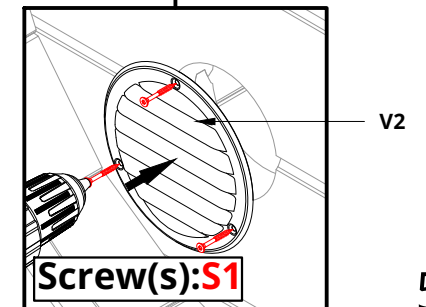
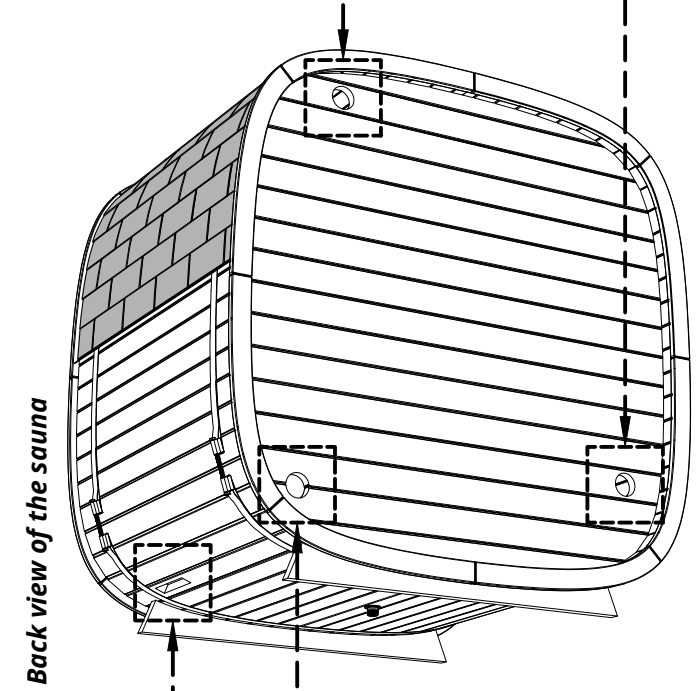
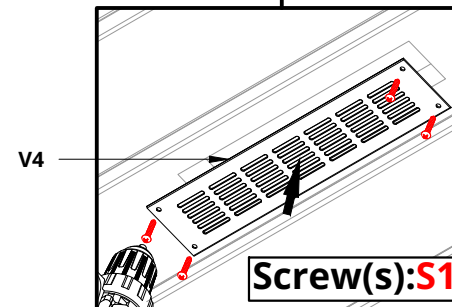
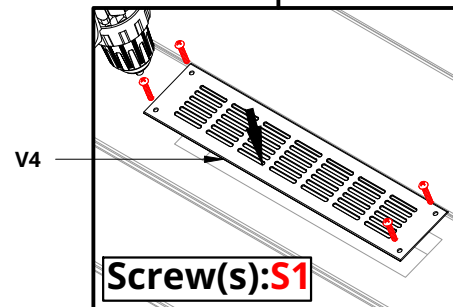
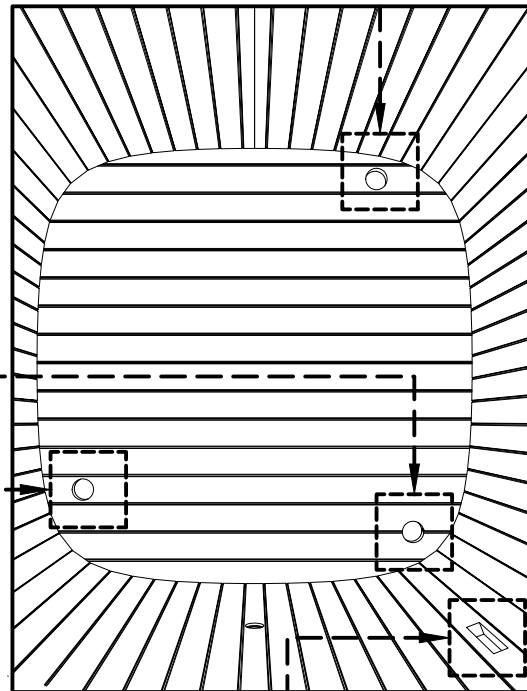
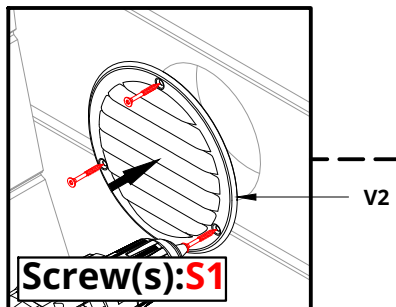
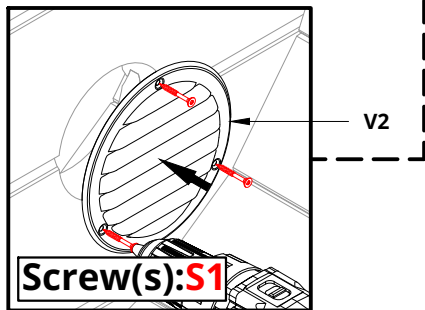
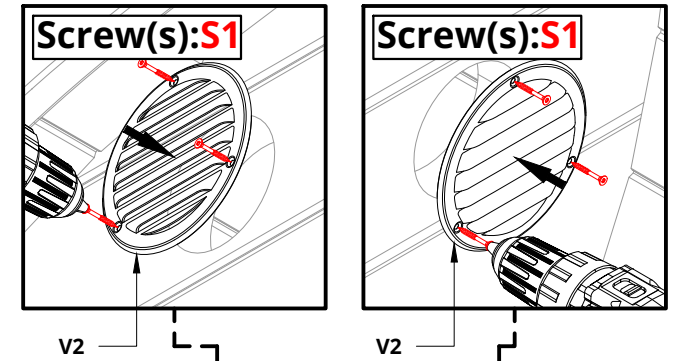
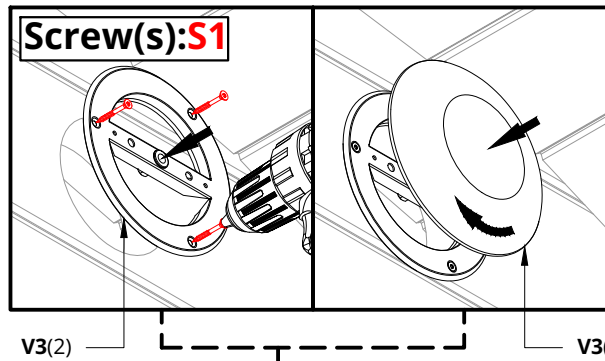
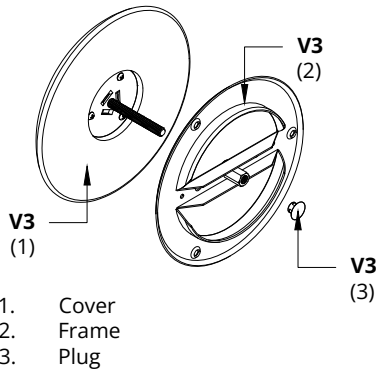

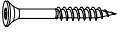
Screw(s)*	Name:	Quantity:
	S6.2	18
	S2	14

*Screw dimensions - exterior construction detail list

NB! use a level



Please countersink the screw head(s)!

- Insert hole cover P if they are not attached and install the door handle and lock!
- Remove the front wall connection strips!
- Install the door from the inside!
- Install windows (If ordered)(Only for woodwall)!
- Install door moldings!

Insert hole cover P if they are not attached!

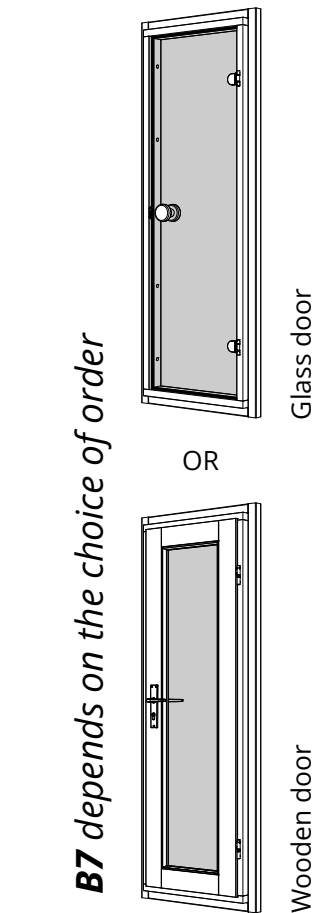
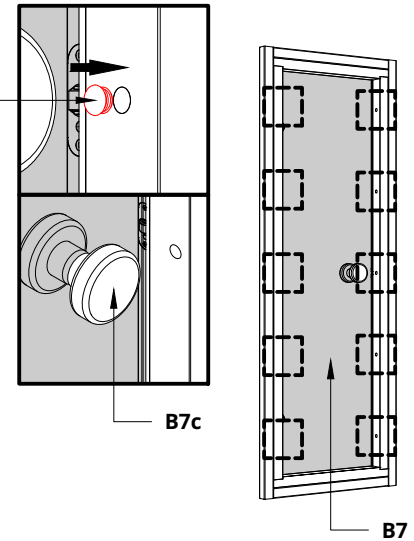

Remove the front wall connection strips

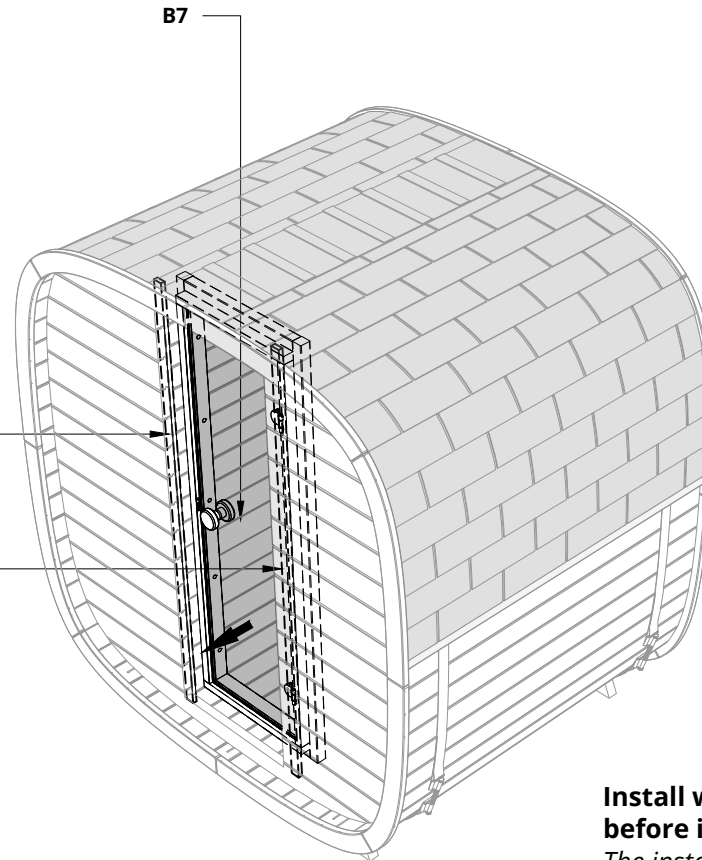

Suggestions!

Drill small hole(s) for the screws in the door moldings before screwing.

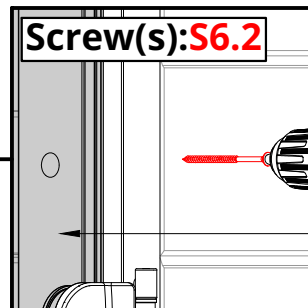
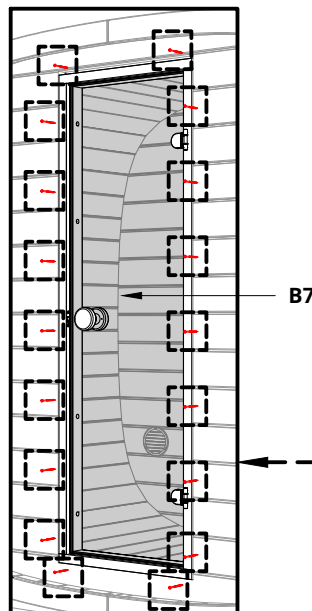

Install windows (If ordered), before installing door moldings!
The installation begins in chapter 5.4.

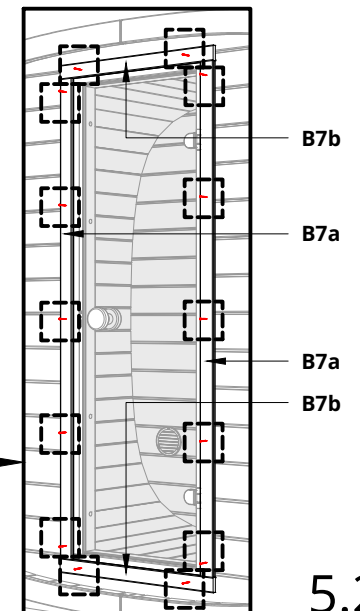
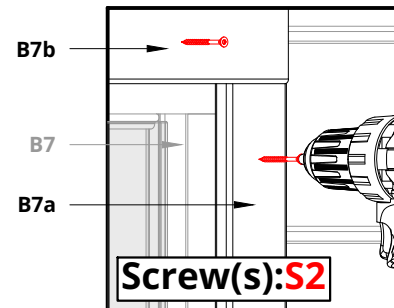

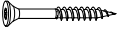
Screw(s)*	Name:	Quantity:
	S6.2	14
	S3.2	14

*Screw dimensions - exterior construction detail list

Door installation for the front glass wall!
Please countersink the screw head(s)!

Insert hole cover P if they are not attached and install the door handle!
Install the door from the inside and install door moldings!

NB! use a level



Insert hole cover P if they are not attached!

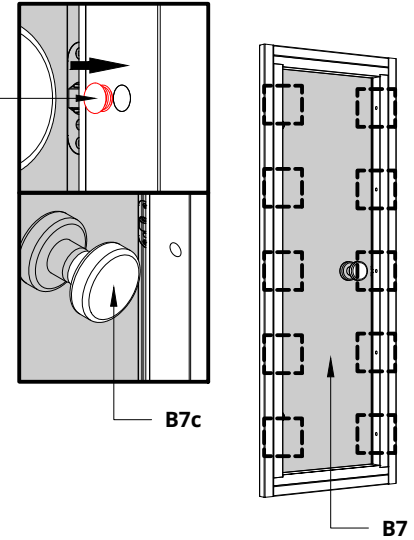

B7 depends on the choice of order

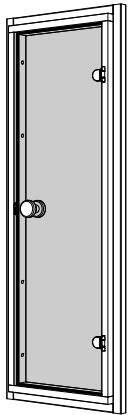

Glass door

OR

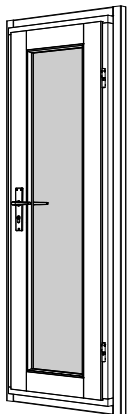

Wooden door

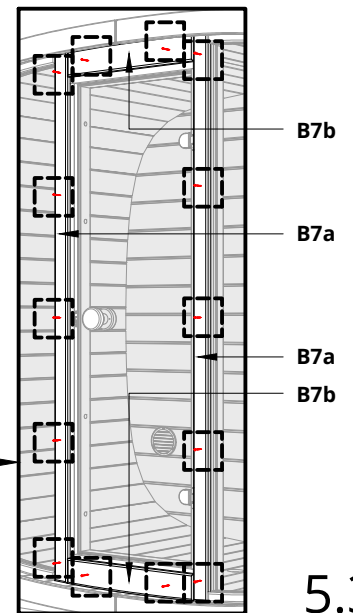
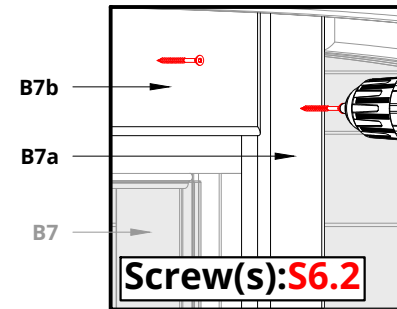
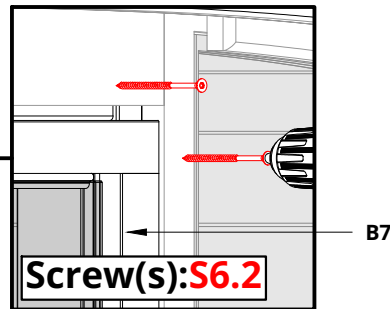
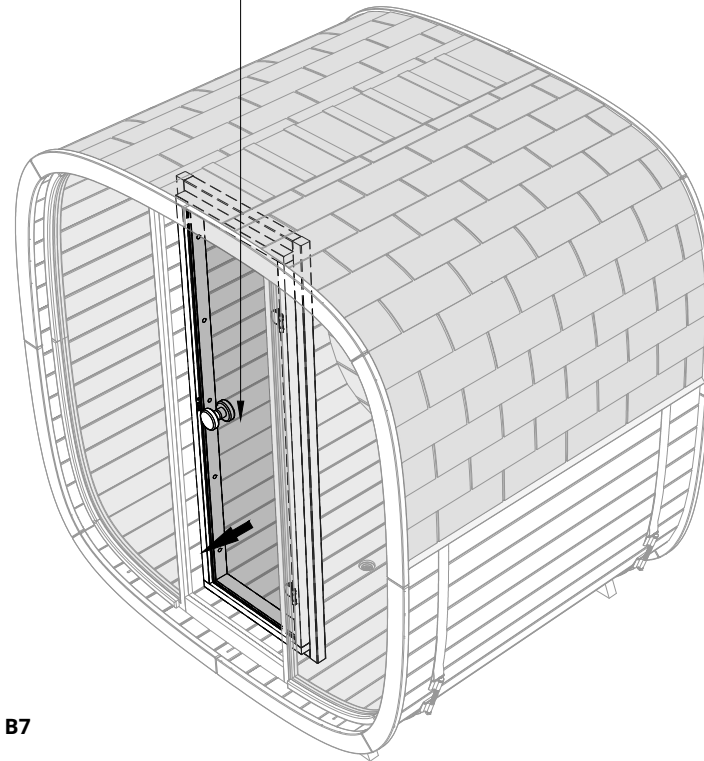
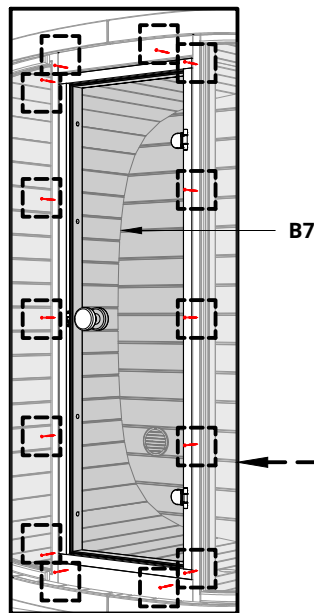

ADJUSTMENT OF THE ROLLER-LOCK

Tools required for adjustment:

- PH2 screwdriver required

Adjustment guide:

- The roller lock can be adjusted by turning the screw indicated by the **red arrow** (shown in Pic.1).
- Turning **clockwise** moves the roller inward (shown by **red arrows** in pic.2) and turning **counter-clockwise** moves the roller outward (shown by **blue arrows** in pic.2).
- The roller should be adjusted so that the **glass moves freely** behind the roller without applying force.
- The roller lock adjustable screw must be always on the upper side of the roll, otherwise the door may get stuck.

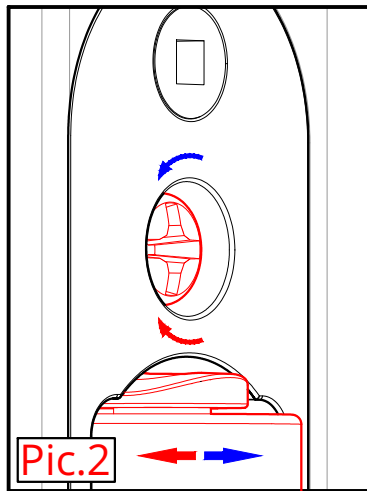
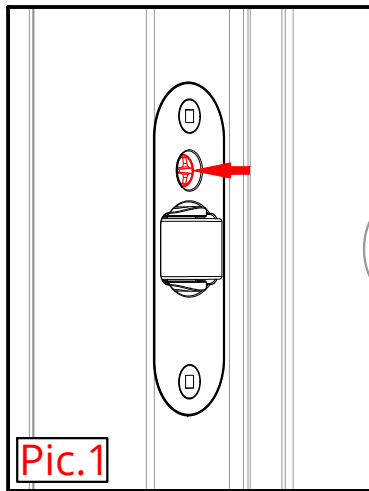

ADJUSTING THE HINGES

Tools required for adjustment:

- T30 (Torx30) Allen wrench or hexagon Bit T30 (Torx30)
- Cordless drill (if Torx Allen wrench is not available)

Adjustment guide:

- Remove plastic from hinges. To remove plastic, start lifting from the locations indicated by the **red arrows** (shown in Pic.1).
- Loosen the bolt slightly (shown in Pic.2). (**DO NOT OPEN COMPLETELY**)
- If both hinge bolts are slightly loosened, then it is possible to move the glass in the directions shown in Pic.3.
- If the glass is set to the required distance, the bolts must be tightened again (shown in Pic.3). **Put the cover back on!**

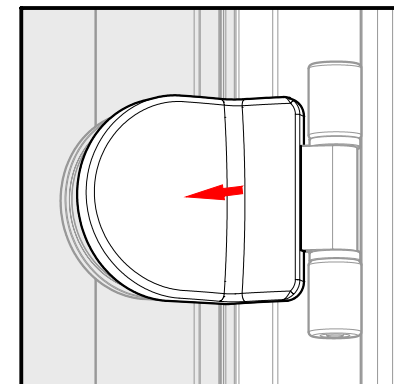
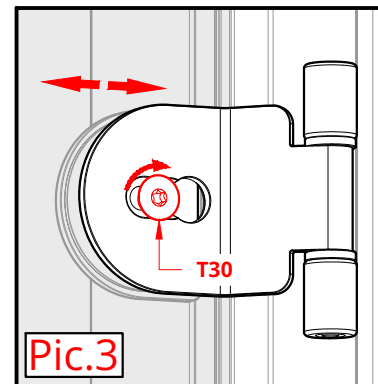
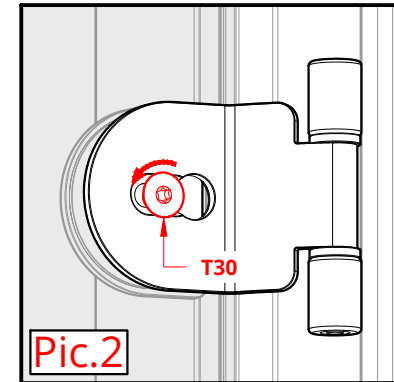
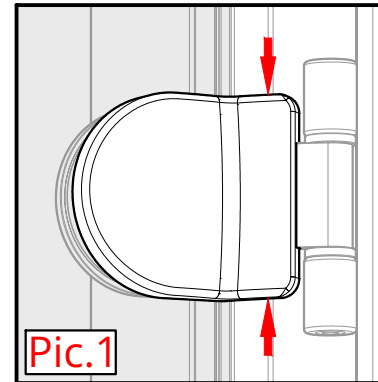

ADJUSTING ABLOY HINGES FOR GLASS DOORS

Features:

- The ABLOY FL 65 SSD Fe is a glass door hinge with lateral adjustment of +/- 3 mm.
- The hinge load capacity is approximately 40 kg when using two hinges.

Tools required for adjustment:

- 5mm Allen wrench or hexagon Bit SW5
- 3mm Allen wrench or hexagon Bit SW3
- Cordless drill (if Allen wrenches (*hexagon wrenches*) are not available)

Adjustment guide:

- Remove the plastic cover from the hinges (*Cover removal, in the direction indicated by the arrow as shown in the Pic.1*). Loosen the bolt slightly (*shown in the Pic.2*) (**DO NOT UNSCREW COMPLETELY**).

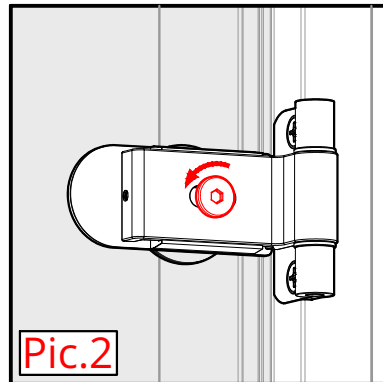
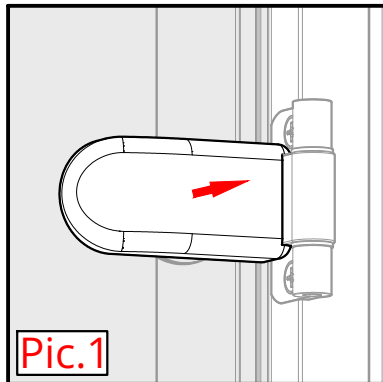

- To adjust the hinges, you need to turn the screws (*shown in the Pic.3 and 4*) with a 3mm allen wrench or a hexagon bit SW3.

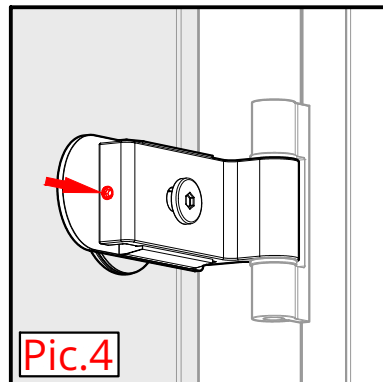
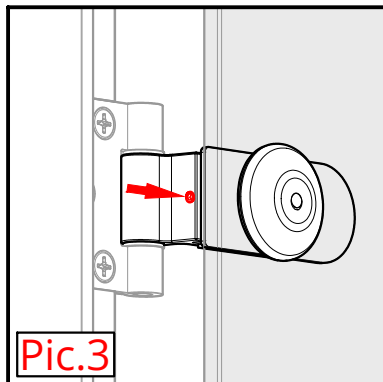

The direction of the glass movement depends on the direction the screw is turned (*assuming the screw on the other side has been loosened*):

- Turning the screw **clockwise** (*shown by red arrows in pic. 5 and 6*), the glass moves closer to the hinges.
- Turning the screw **counterclockwise** (*shown by blue arrows in pic. 5 and 6*), the glass moves away from the hinges.
- Afterwards, tighten the screw on the other side.

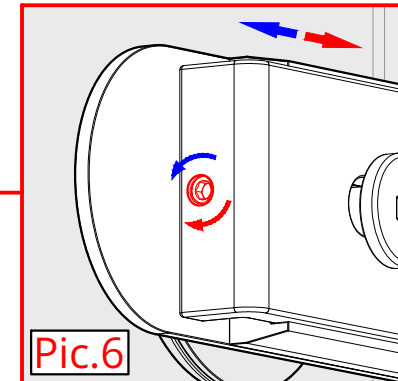
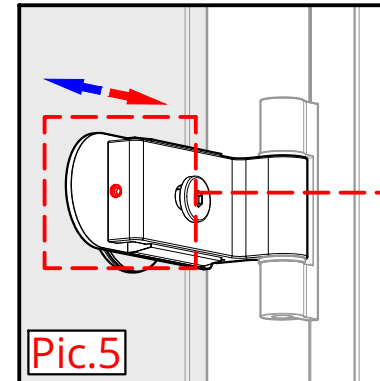

- If the hinges are adjusted, tighten the larger bolt. **Put the cover back on!**

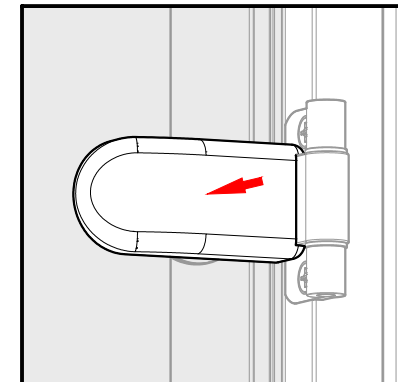
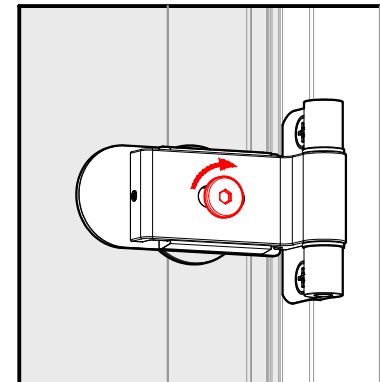

General recommendations:

When adjusting the hinge, it is important to be careful not to damage the glass or the hinge itself.

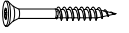

Screw(s)*	Name:	Quantity:
	S7	14

*Screw dimensions - Bench assembly detail list

NB! use a level

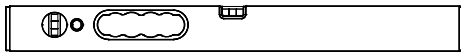

Please countersink the screw head(s)!
Measured from the center board of the floor!
Use glue between the square wood K... and the wall!

Install square woods for benches!

BLACK Cube Classic		
a	402 mm	~ 1'-3 13/16"
b	852 mm	~ 2'-9 9/16"
c	~7 mm	~ 0'-0 1/4"
Distance - d	~768 mm	~ 2'-6 1/4"
Distance - e	~460 mm	~ 1'-6 1/8"

Front view (from inside)

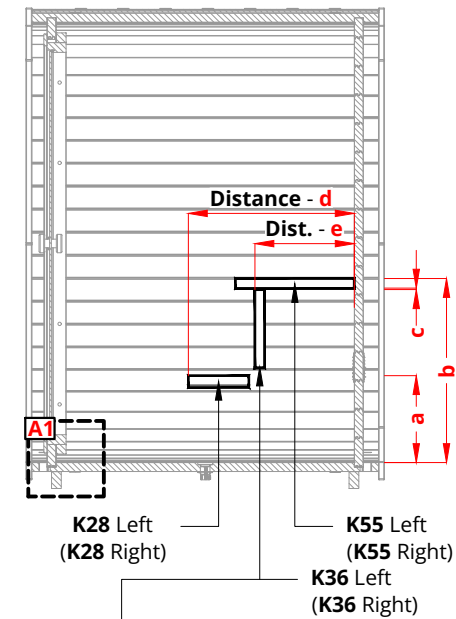
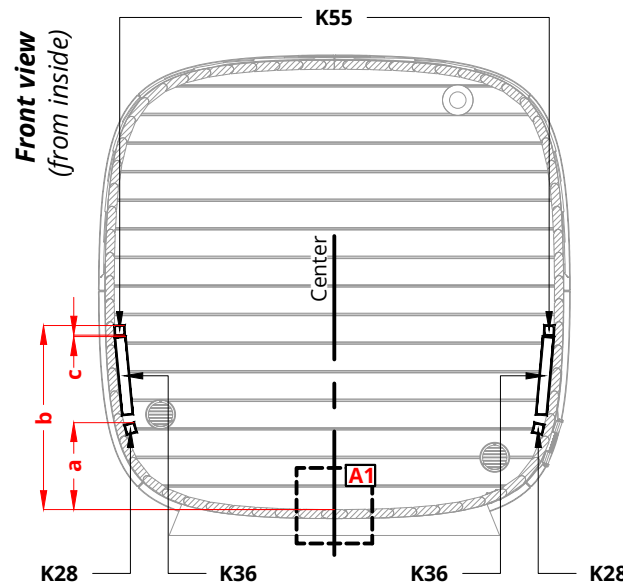
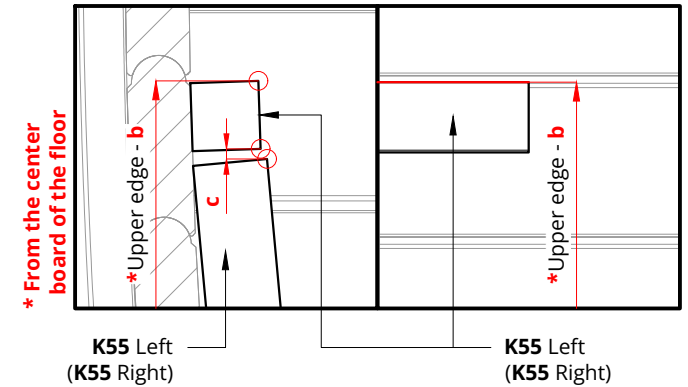
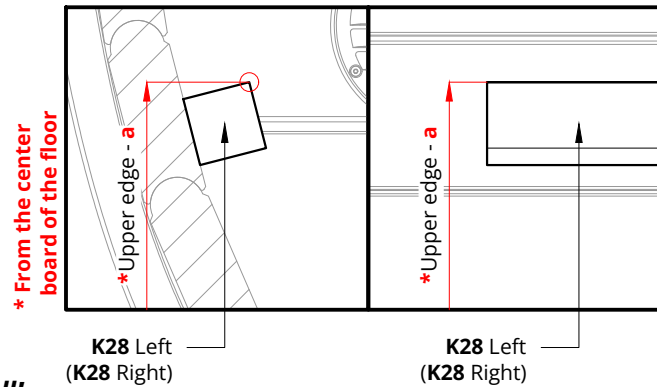
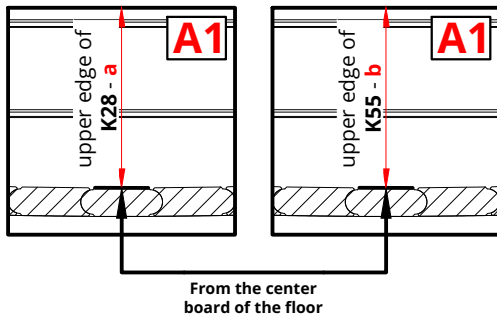

Notice!

Drill 4mm hole in the K... square woods before screwing.

Use glue!

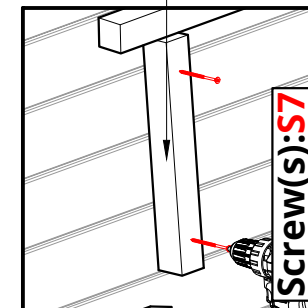
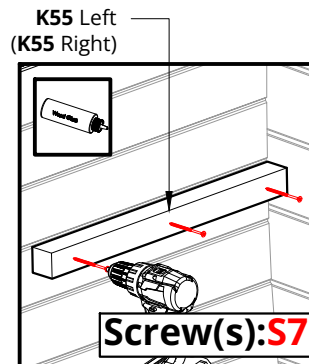
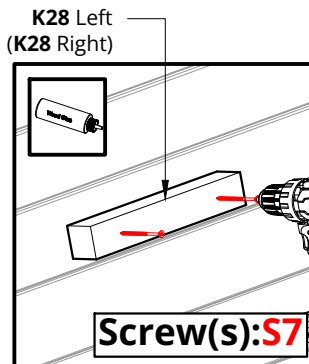
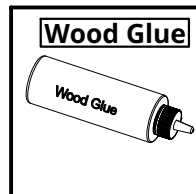
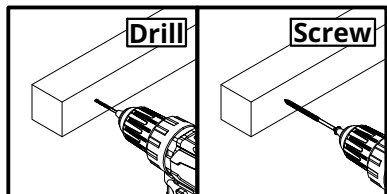

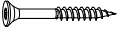
Screw(s)*	Name:	Quantity:
	S7	14
	S5	4

NB! use a level

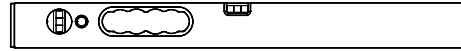

*Screw dimensions - Bench assembly detail list

Please countersink the screw head(s)!
Use glue between the square wood K... and the wall!
The square wood(s) K45 are longer and must be cut to the correct size!

Install the upper bench and the square wood K10 it under the bench as shown in the picture!
Install the lower bench!
Install the Lower bench legs K45!

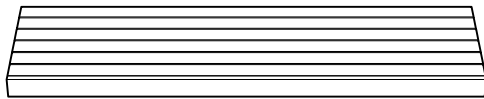
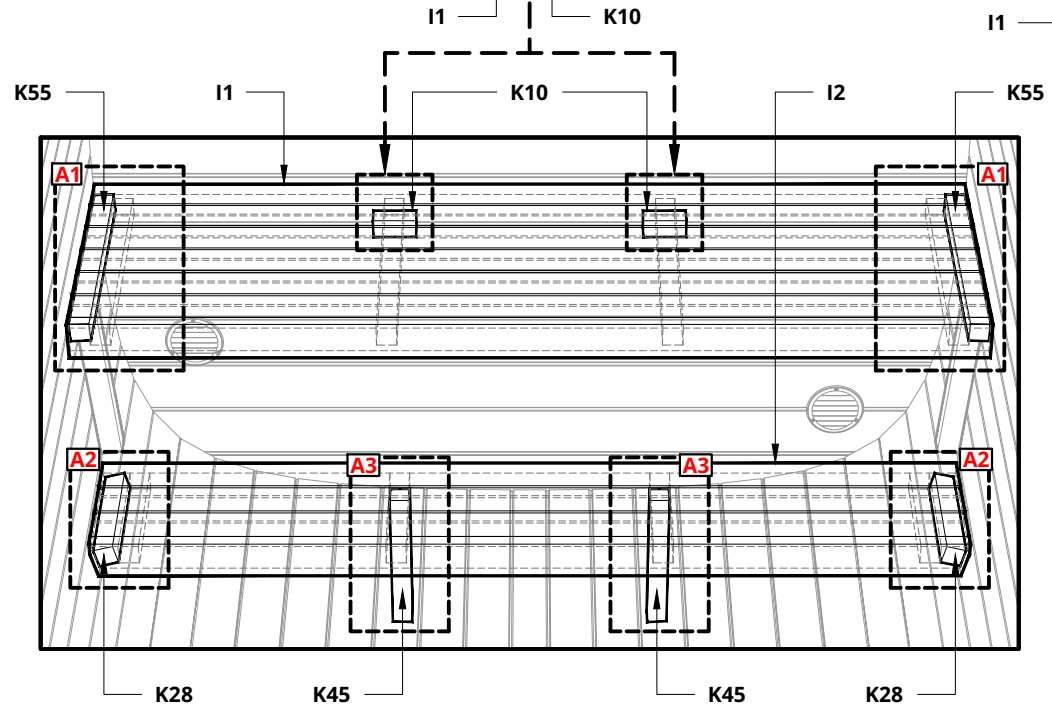
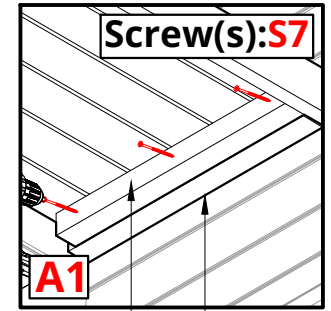
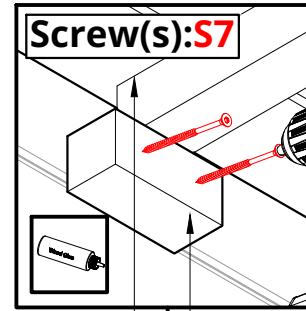

Upper bench I1

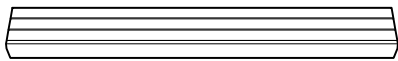
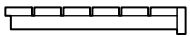

Lower bench I2

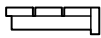

Notice!

Drill 4mm hole in the K... square woods before screwing.

Use glue!

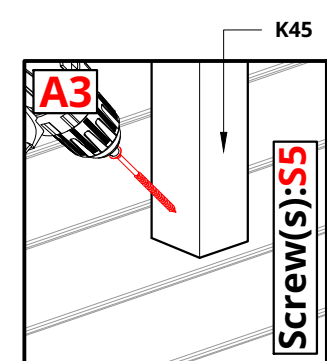
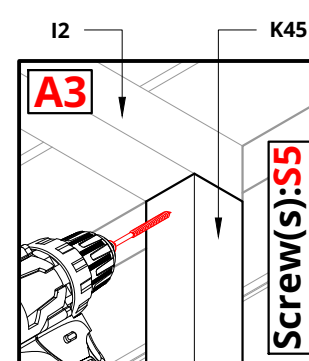
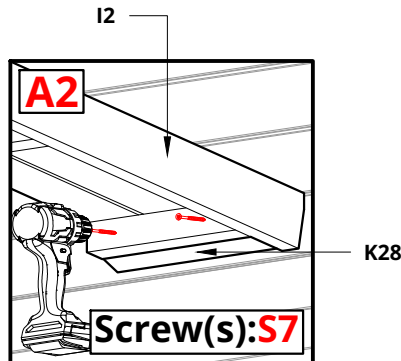
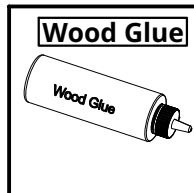
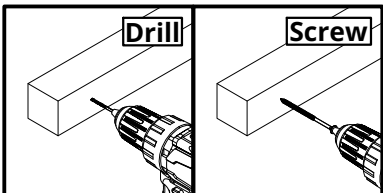

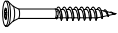
Screw(s)* 	Name:	Quantity:
	S5	8

*Screw dimensions - Bench assembly detail list

NB! use a level

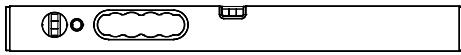

Please countersink the screw head(s)!
The cover board(s) D2 are longer and must be cut to the correct size!

Install the lower bench legs cover boards D2!
Install the bench skirt!

BLACK Cube Classic		
*a	~30 mm	~ 0'-1 3/16"
*b	~13 mm	~ 0'-0 1/2"
c	~8 mm	~ 0'-0 5/16"

*Recommended!!!

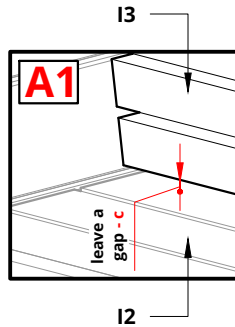

Bench skirt (back) I3

Notice!

Drill 4mm hole in the K... square woods before screwing.

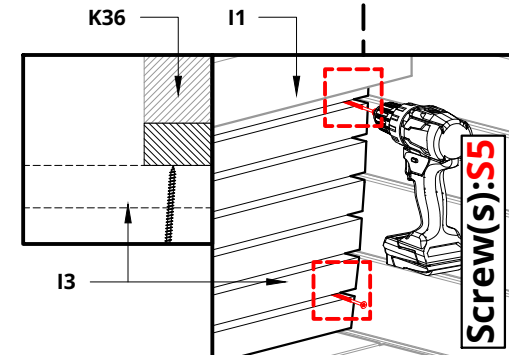
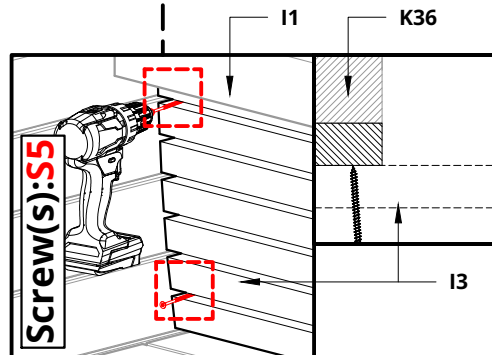
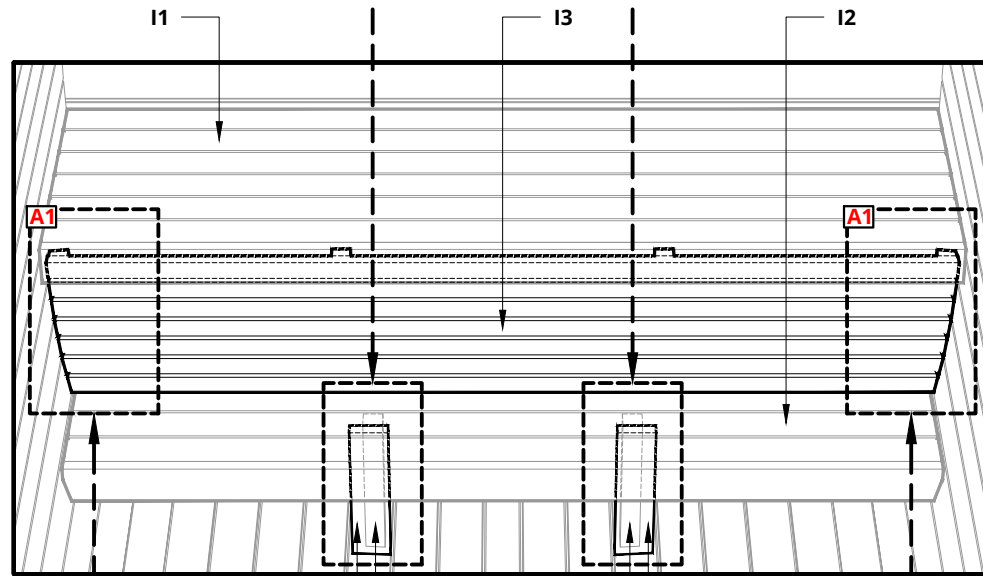
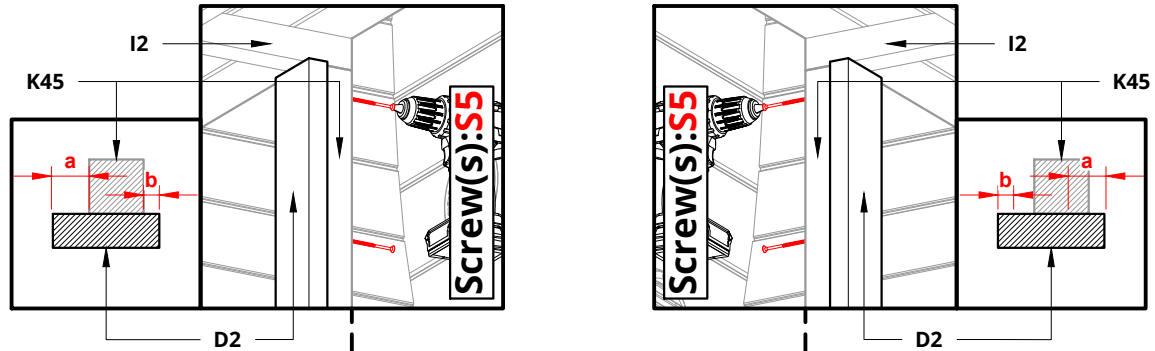
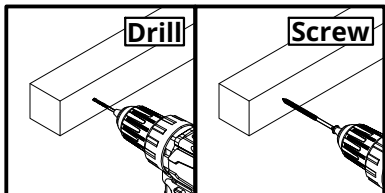

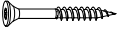
Screw(s)*	Name:	Quantity:
	S7	2
	S5	5

*Screw dimensions - Bench assembly detail list

NB! use a level

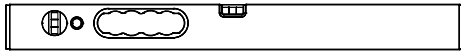

Please countersink the screw head(s)!
Measured from the center board of the floor!
Use glue between the square wood K... and the wall!

Install square woods for benches!

BLACK Cube Classic		
a	402 mm	~ 1'-3 13/16"
b	852 mm	~ 2'-9 9/16"
Distance - c	~768 mm	~ 2'-6 1/4"
Distance - d	~225 mm	~ 0'-8 7/8"

Front view (from inside)

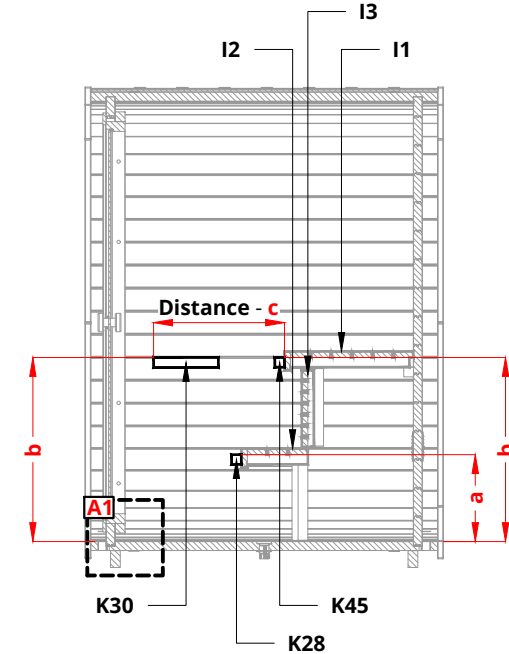
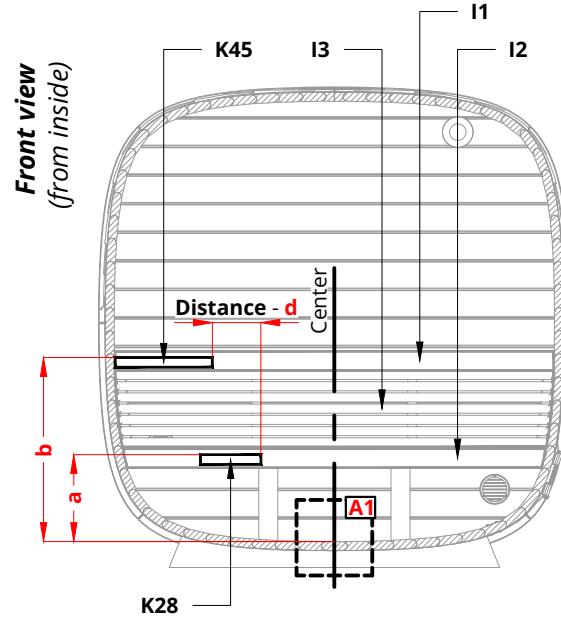
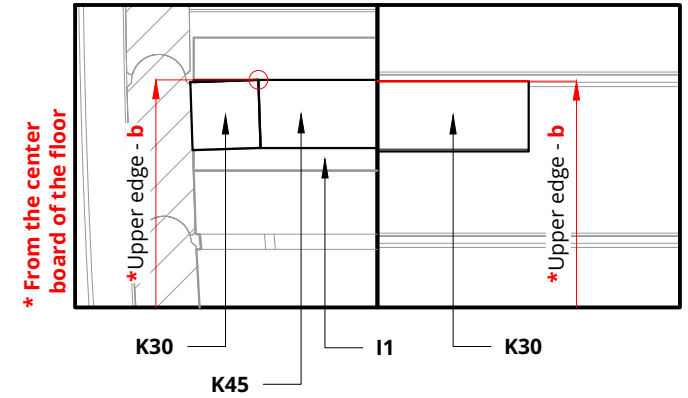
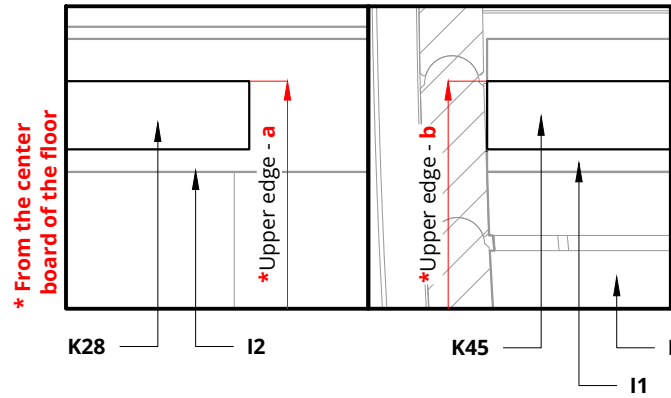
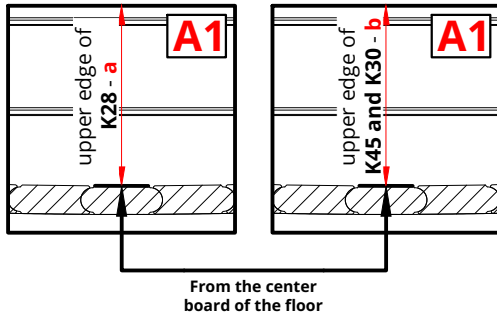

Notice!

Drill 4mm hole in the K... square woods before screwing.

Use glue!

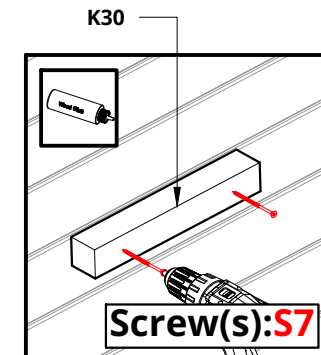
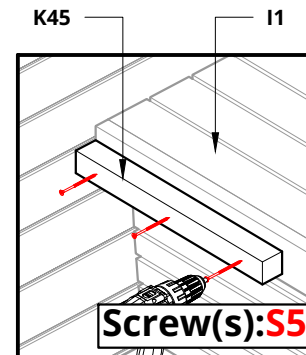
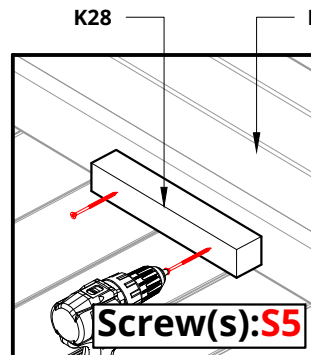
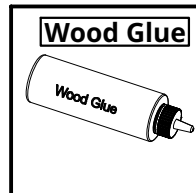
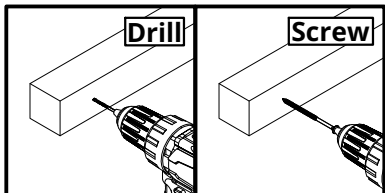

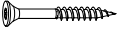
Screw(s)*	Name:	Quantity:
	S7	3
	S5	5

*Screw dimensions - Bench assembly detail list

NB! use a level

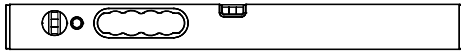

Please countersink the screw head(s)!
The square wood(s) K90 are longer and must be cut to the correct size!

Install the upper bench and add support(s) to keep the bench level!
Measure the depth of the upper bench leg K90!
Mark the position of the bench leg K90!
Measure the length of the bench leg(s) K90 from the marked position downwards!
Cut bench leg to the correct size!
Remove supports and install bench leg(s) 90!

BLACK Cube Classic		
a	~25 mm	~ 0'-1"

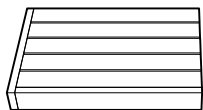

Upper bench I4

Notice!

Drill 4mm hole in the K... square woods before screwing.

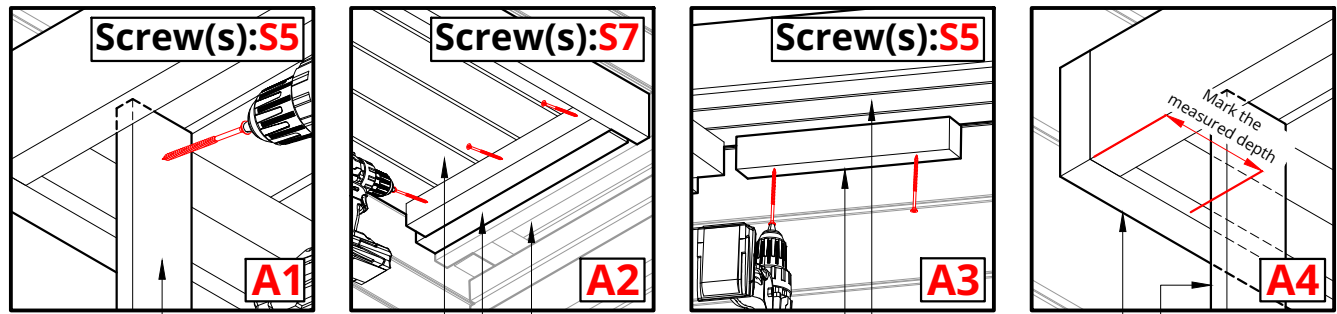
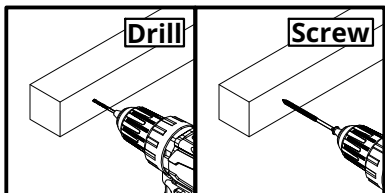

Support

I4

I1

K30

I4

Support

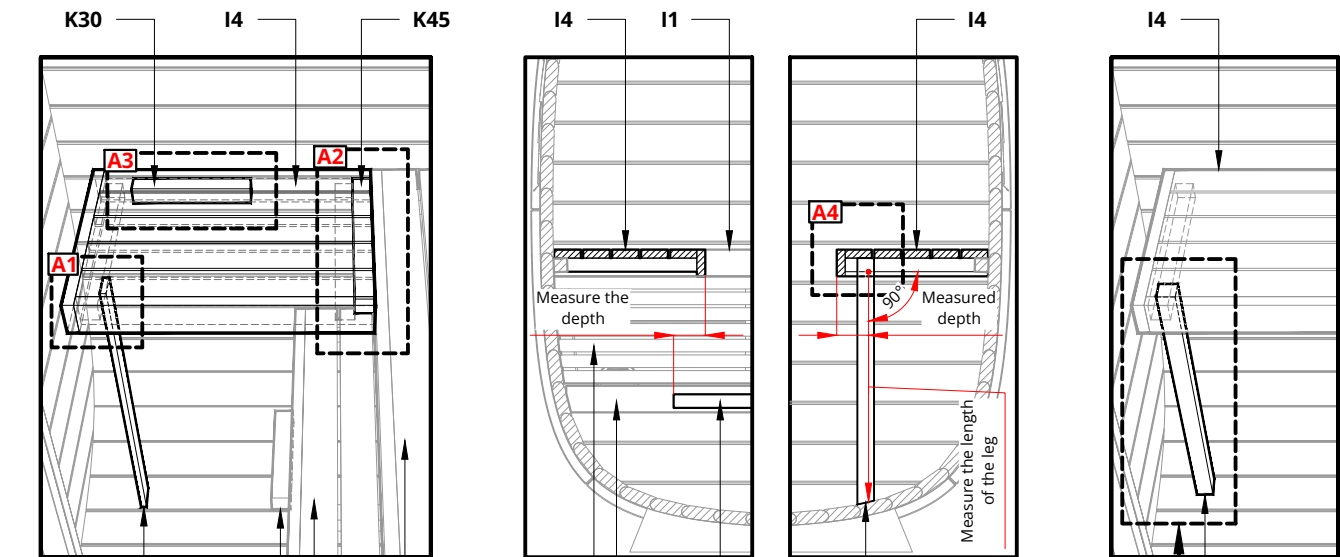

Support

K28

I2

I1

I3

I2

K28

Support

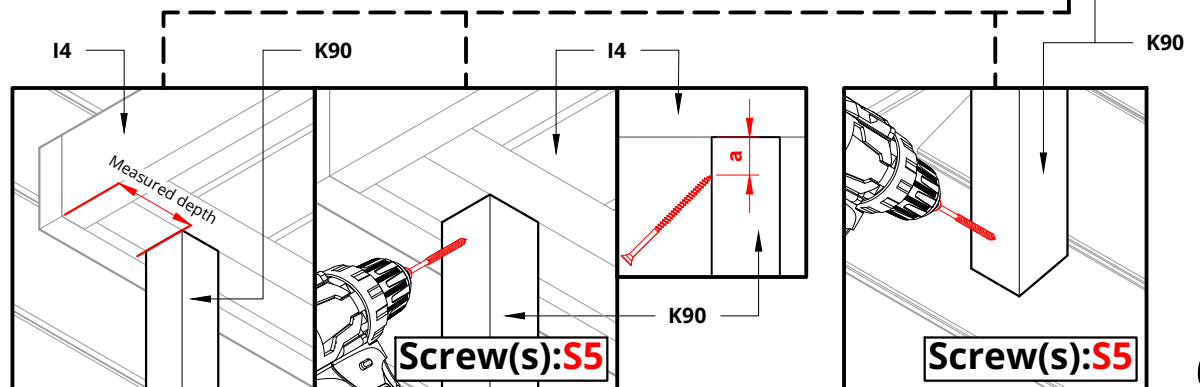

Screw(s):S5

Screw(s):S5

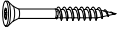
Screw(s)* 	Name: S5	Quantity: 4
--	--------------------	-----------------------

*Screw dimensions - Bench assembly detail list

NB! use a level

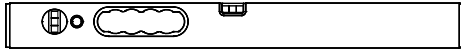

Please countersink the screw head(s)!
The cover board(s) D1 and D2 are longer, they must be cut to the correct size!

Install the bench leg K90 cover board(s) D1 and D2!

BLACK Cube Classic		
a	28 mm	~ 0'-1 1/8"
b	~450 mm	~ 1'-5 11/16"

Notice!

Drill 4mm hole in the K... square woods before screwing.

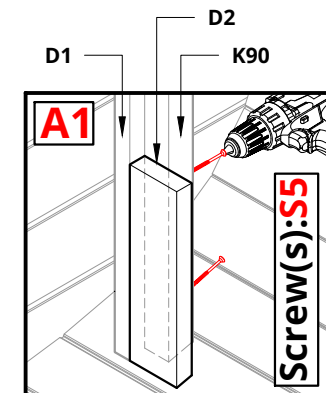
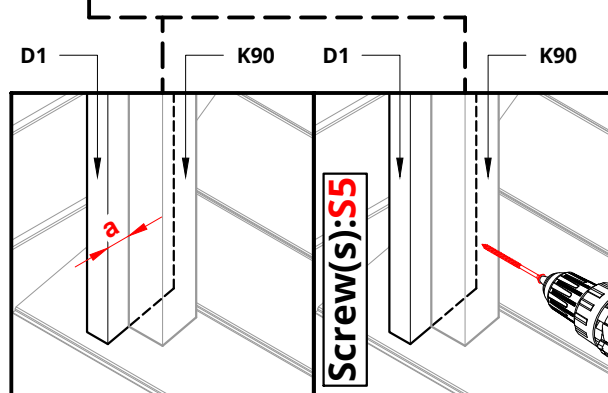
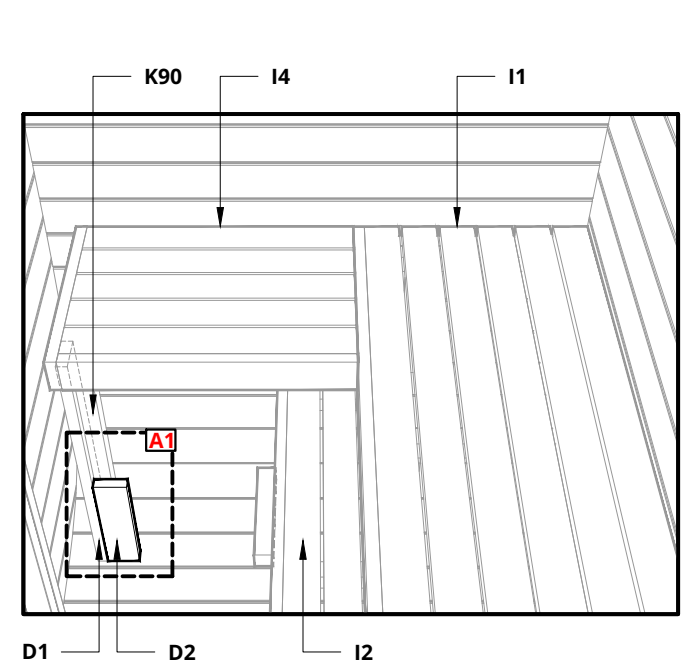
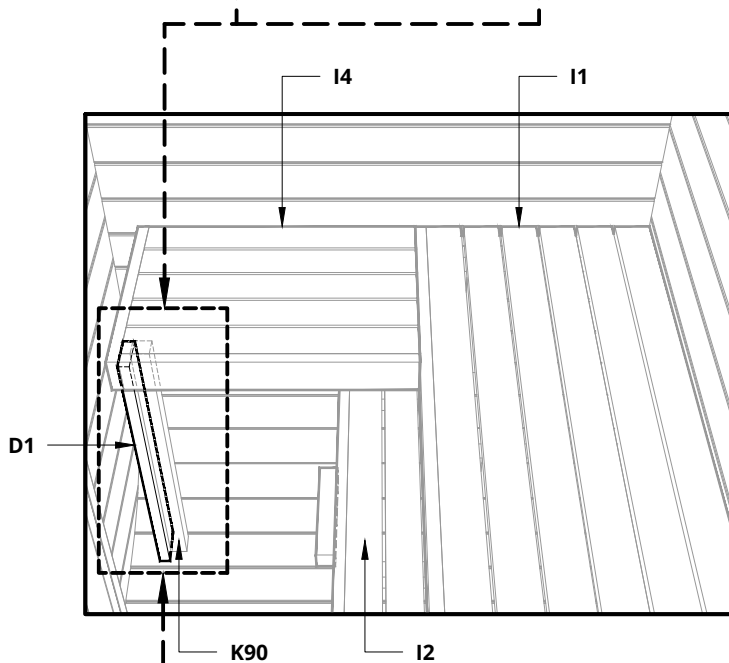
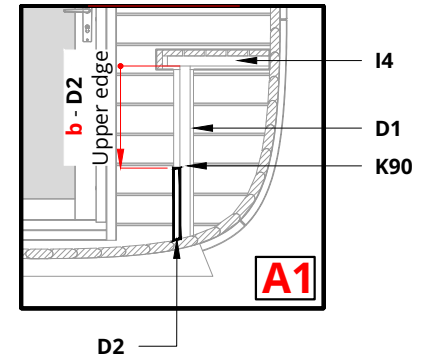
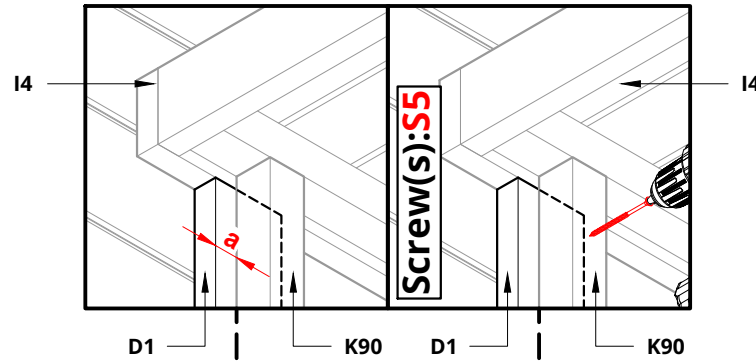
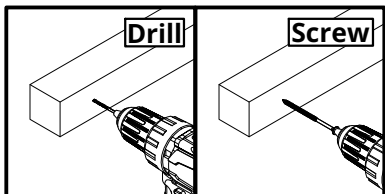

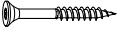
Screw(s)*	Name:	Quantity:
	S7	2
	S5	4

*Screw dimensions - Bench assembly detail list

NB! use a level

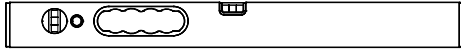

Please countersink the screw head(s)!
The square wood(s) K45 are longer, they must be cut to the correct size!

Install the Lower bench!
Install some supports to keep the bench level!
Measure the length of the bench leg(s)K45!
Remove support(s)!
Install the leg(s) K45 of the bench!

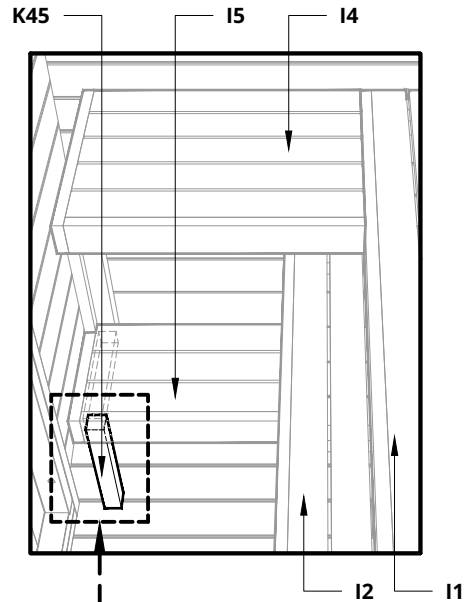
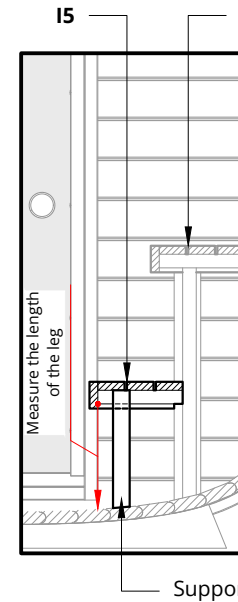
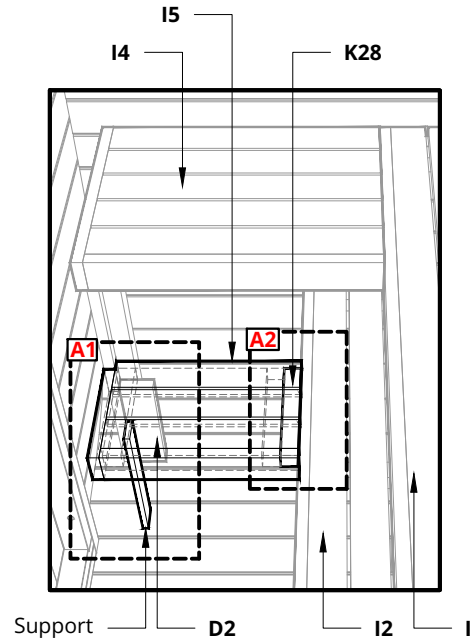
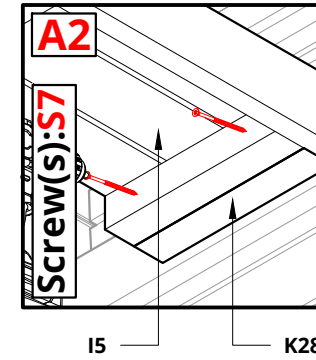
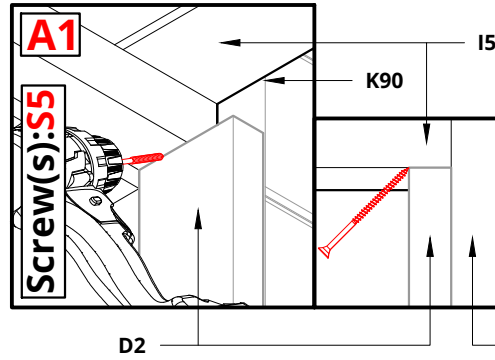
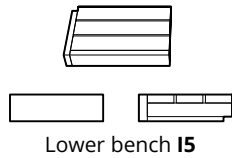

Notice!

Drill 4mm hole in the K... square woods before screwing.

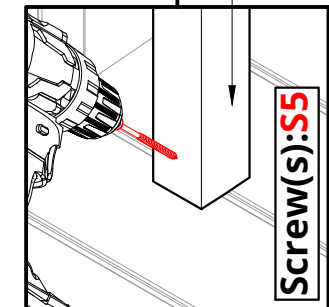
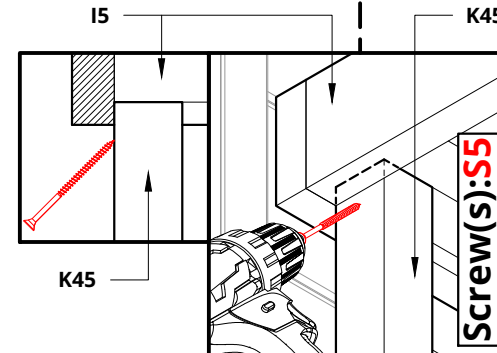
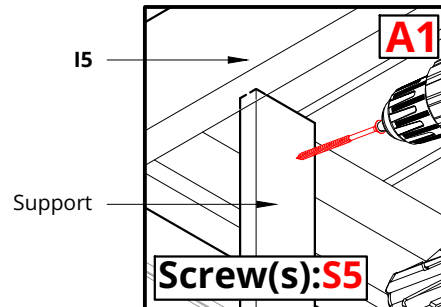
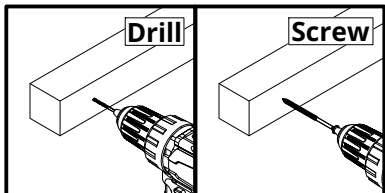

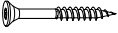
Screw(s)* 	Name: S5	Quantity: 6
--	--------------------	-----------------------

*Screw dimensions - Bench assembly detail list

NB! use a level

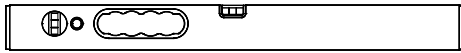

Please countersink the screw head(s)!
The cover board(s) D2 are longer and must be cut to the correct size!

Install the lower bench legs cover boards D2!
Install the upper bench leg cover board D2!
(If bench skirt is not ordered)

To install bench skirt, follow chapter 8.1!

BLACK Cube Classic		
a	28 mm	~ 0'-1 1/8"
b	~ 3 mm	~ 0'-0 1/8"

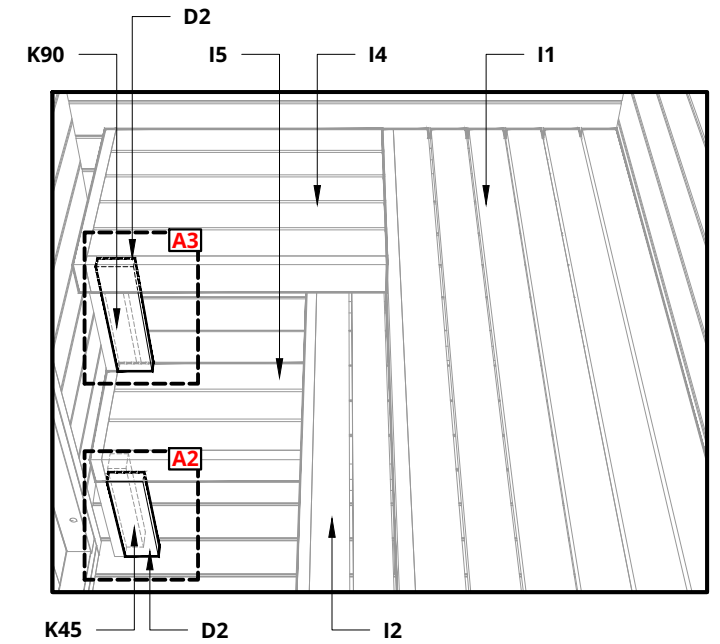
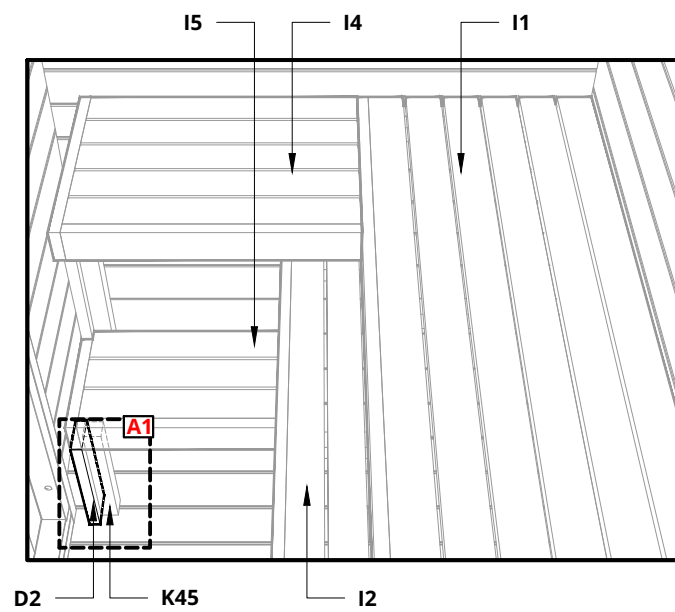
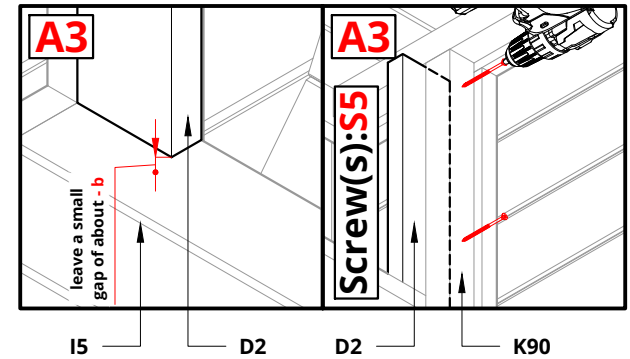
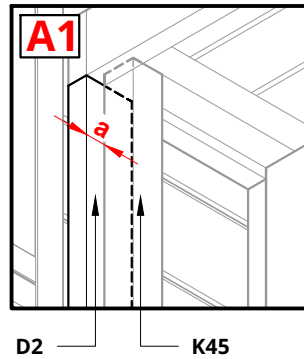

Notice!

Drill 4mm hole in the K... square woods before screwing.

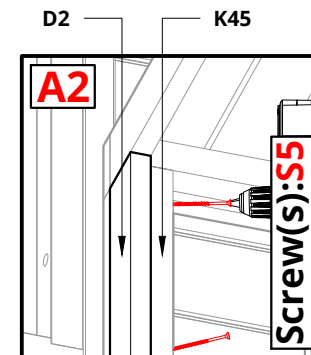
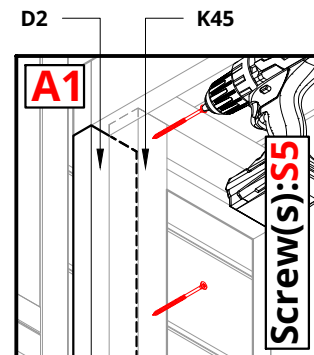
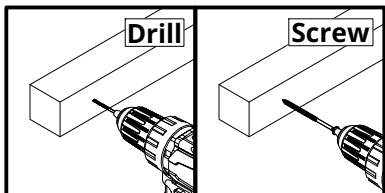

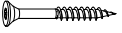
Screw(s)*	Name:	Quantity:
	S5	5
	S2	2

*Screw dimensions - Bench assembly detail list

NB! use a level

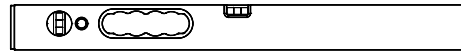

BLACK Cube Classic		
*a	360 mm	~ 1'-2 3/16"
b	~55 mm	~ 0'-2 3/16"

*Recommended!!!

Install the bench backrest(s) I5 and I6!
Install floor mat F1!

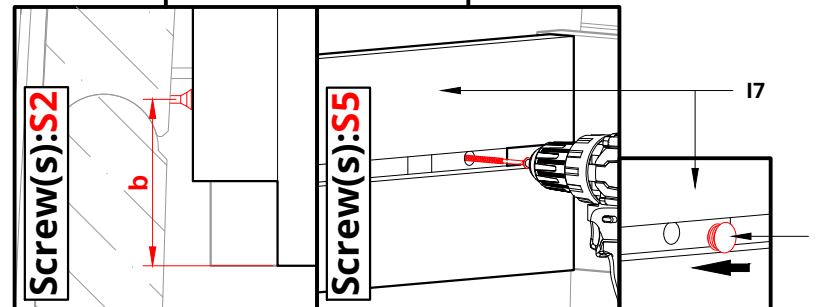
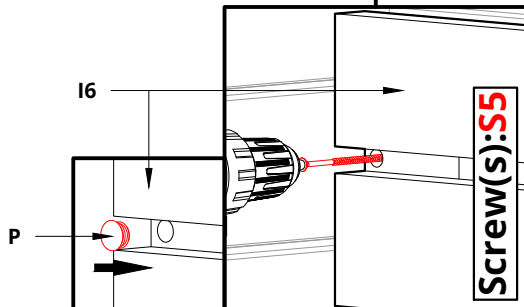
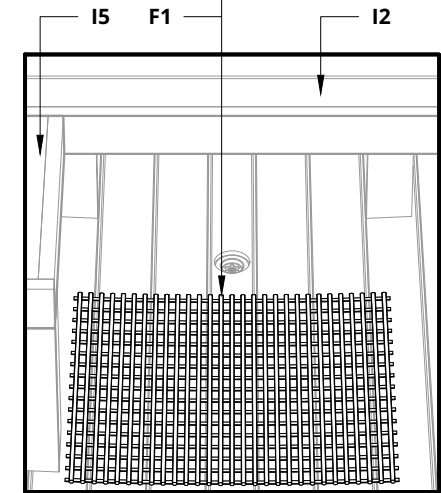
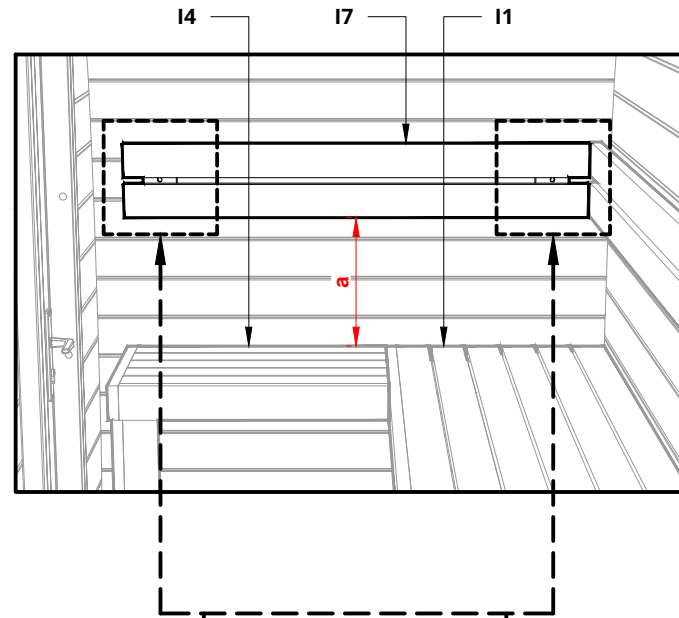
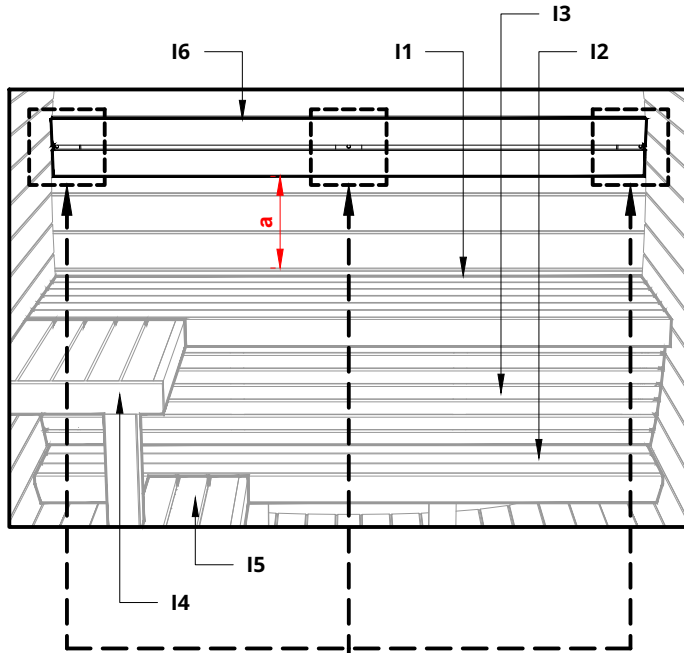
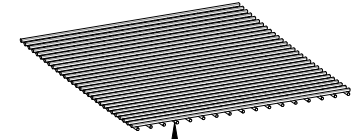

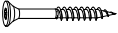
Screw(s)*	Name:	Quantity:
	S7	3
	S5	2
	S3.2	3

NB! use a level



*Screw dimensions - Bench assembly detail list

Install the heater wall mounting module shell H1.1!

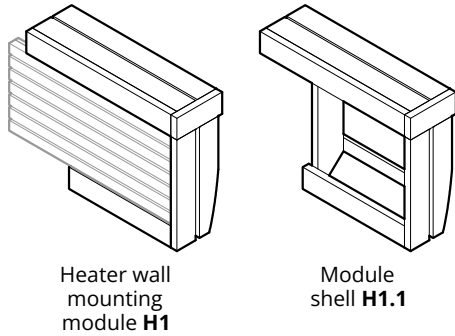

BLACK Cube Classic		
a	880 mm	~ 2'-10 5/8"

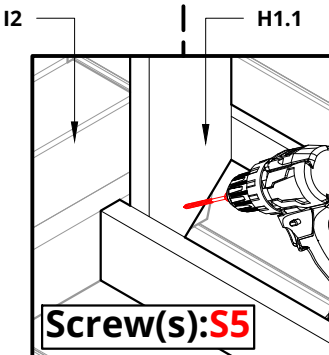
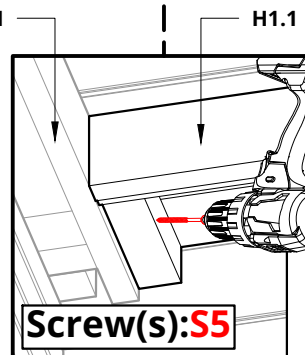
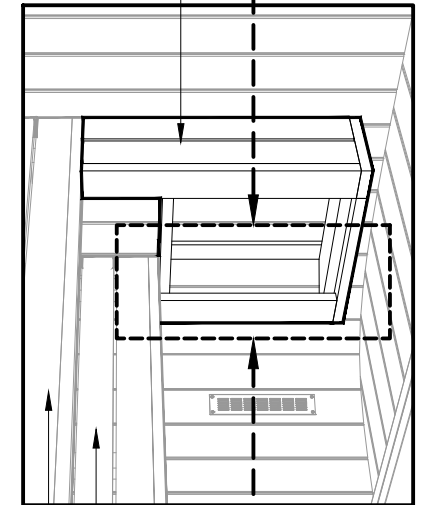
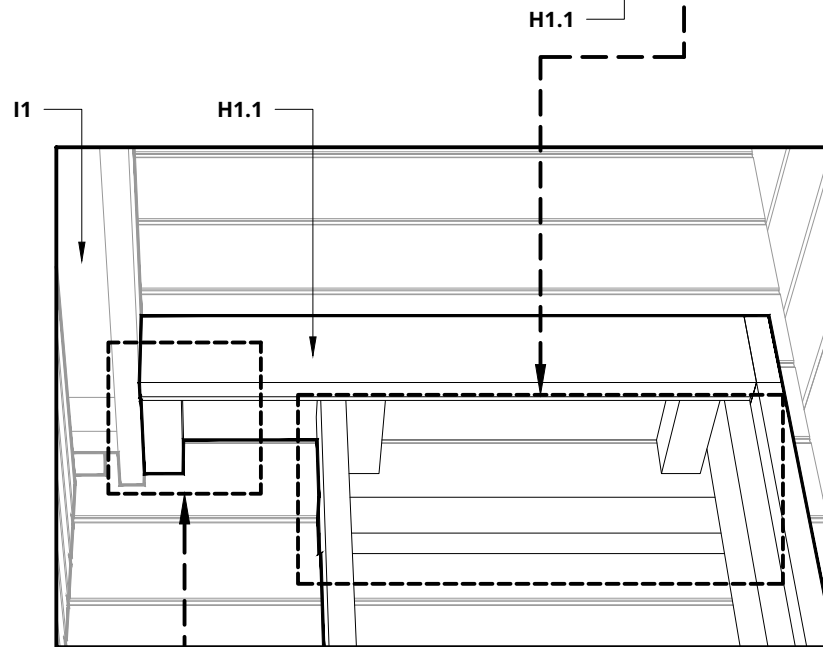
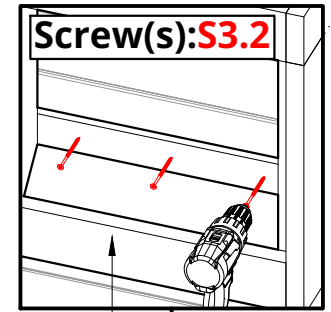
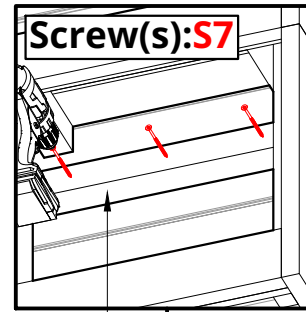
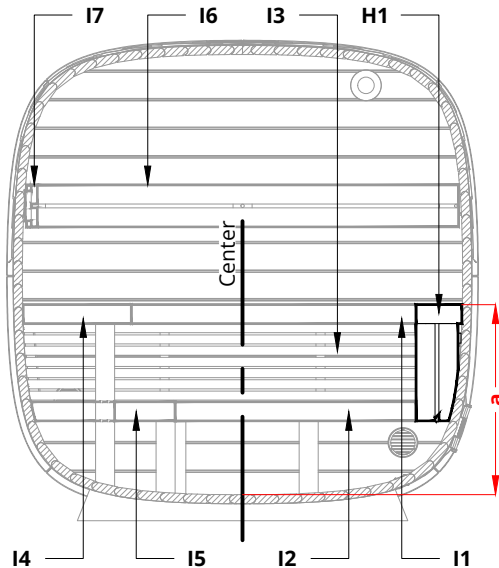

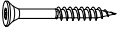
Screw(s)*	Name:	Quantity:
	S5	11

*Screw dimensions - Bench assembly detail list

NB! use a level

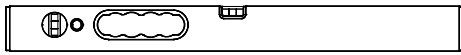

Please countersink the screw head(s)!

Install square wood K36 for the modul grate!
Install the heater wall mounting module shell grate H1.2!

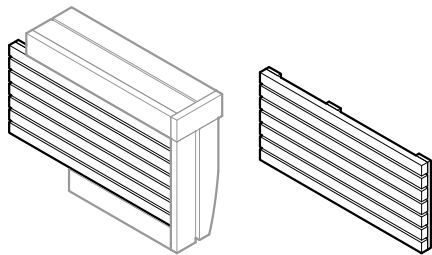

Heater wall mounting module H1

Module grate H1.2

Notice!

Drill 4mm hole in the K... square woods before screwing.

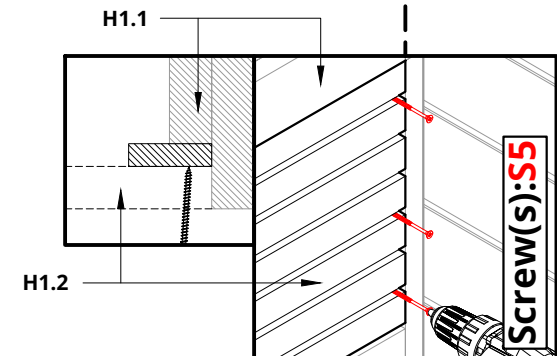
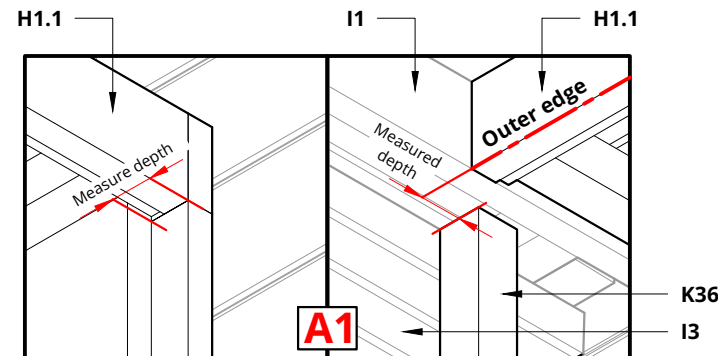
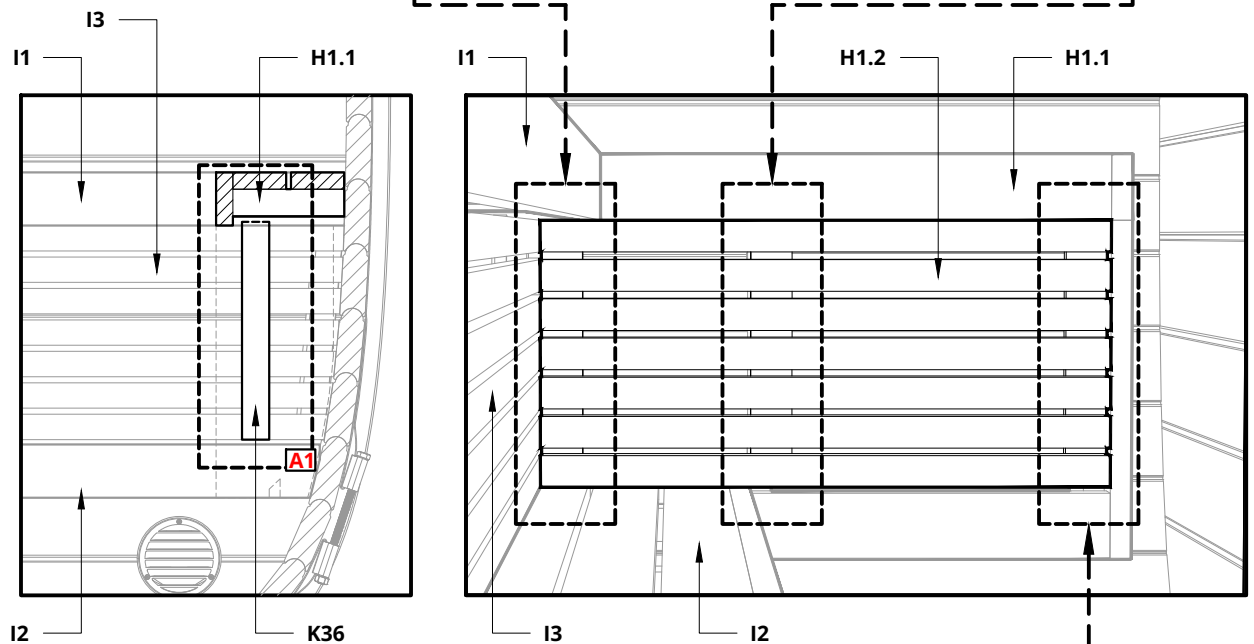
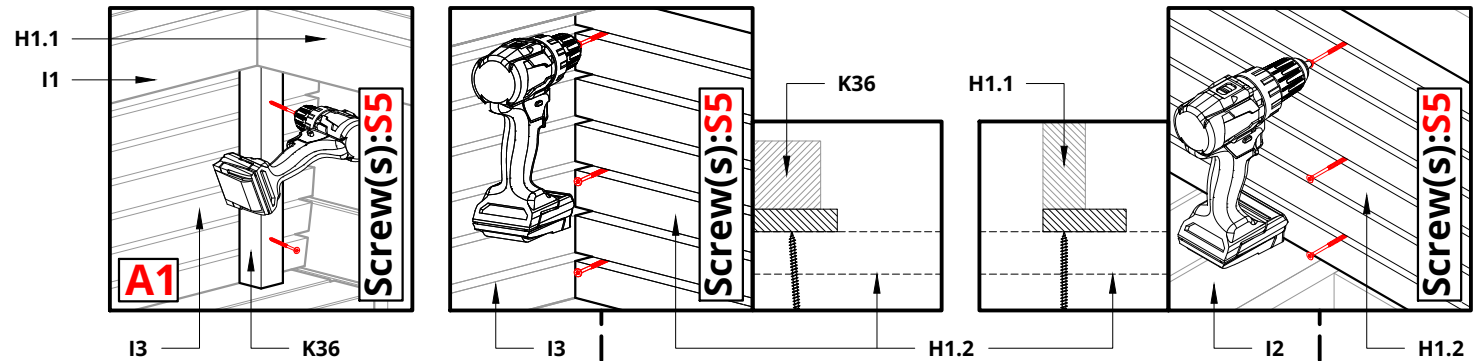
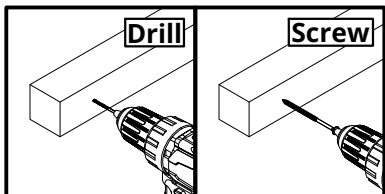

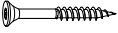
Screw(s)*	Name:	Quantity:
	S5	8

*Screw dimensions - Bench assembly detail list

Please countersink the screw head(s)!

Install the front wall mount H2!

BLACK Cube Classic		
a	18 mm	~ 0'-0 11/16"

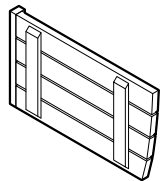
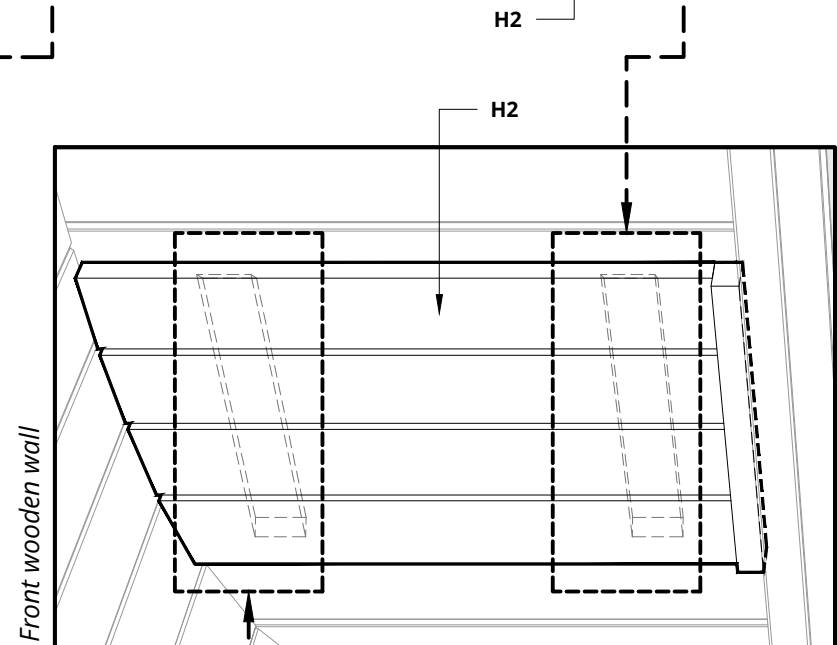
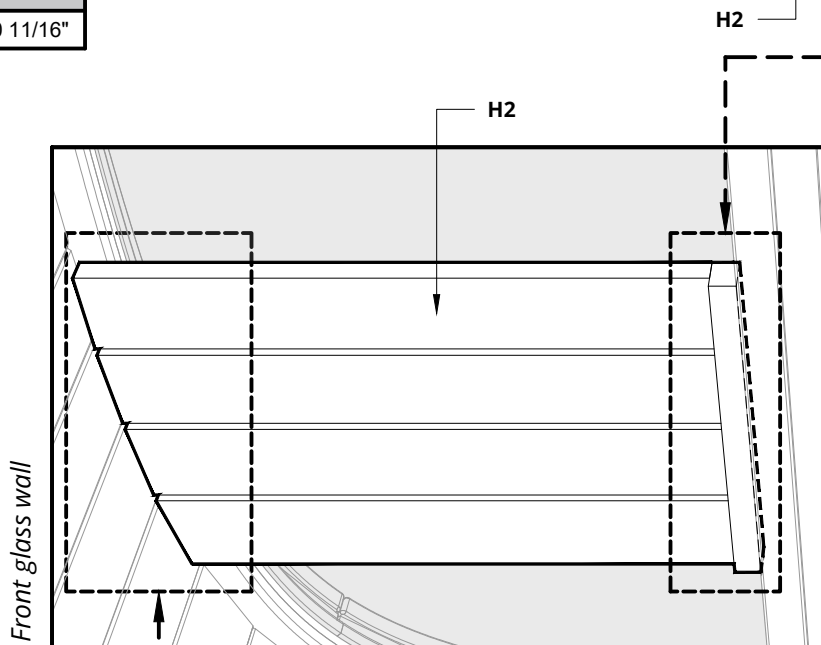
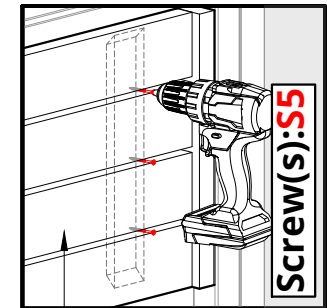
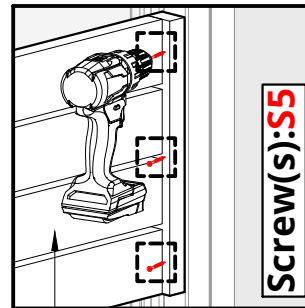
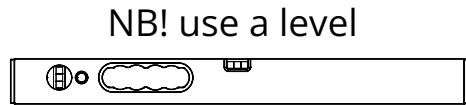

Heater wall mounting module H2

Notice! (Only for glass wall)

Drill 4mm hole in the wood details for screws.

